

The logo for CrustNet features the word "CrustNet" in a bold, brown, sans-serif font. Each letter is filled with a detailed illustration of various soil microorganisms, including fungi, bacteria, and plant roots, set against a dark brown background. The letters are arranged in a single line, with the "C" being significantly larger than the other letters.

CrustNet

A GLOBAL RESEARCH
NETWORK DEVOTED TO A
UNIFIED UNDERSTANDING
OF THE “LIVING SKIN” OF
THE EARTH

PI Group:

Matthew Bowker, Anthony Darrouzet-Nardi, Sasha Reed,
Sierra Gugel, Anita Antoninka, Javier Ceja-Navarro

Version: 10
Date: April 2026

Table of Contents

1.0 Organizational Background and Key Contributors	3
1.1 Primary Points of Contact	3
1.2 External Steering Committee Members	3
1.3 History of CrustNet.....	3
1.4 List of Reviewers.....	3
2.0 Project Overview	5
3.0. Mechanics of Operation	6
3.1 What a Contributor Must Do.....	6
3.2 What a Contributor Will Get (authorship and data usage rules).....	7
3.3 Selecting a Node	9
4.0 Survey and Sampling Methods (All Tiers)	11
4.1 Timing of Sampling.....	11
4.2 Pre-sampling.....	12
4.3 Voucher Specimens	17
4.4 Soil Sampling & Handling General Overview	18
4.5 Minimizing Your Impact - Overview	22
5.0 Sampling Instructions	23
5.1 Site Characterization (mandatory for all Tiers 1-3).....	23
5.2 Tier 1	25
5.3 Tier 2	46
5.4 Tier 3	59
6.0 Data Submission	63
References	64
Additional Resources	65
Appendix 1. How the Leadership Team Can Support Your Node Installation	66
Appendix 2. Suggested Field Sampling Flow	70
Appendix 3. Field Checklist.....	72
Appendix 4. Materials Checklist and Tier 1 Diagrams.....	74
Appendix 5. Tier 2 Checklist (print this double sided and use in the field)	79
Appendix 6. Suggested Labeling Systems	81
Appendix 7. Additional Optional Studies.....	83

Appendix 8. Rainfall reduction shelter design	85
Appendix 9. Rainfall Reduction Shelter Installation Instructions	88
Appendix 10. Instructions for Shipping Imported CrustNet Samples.	92
Appendix 11. Ocular Cover Estimate Guide.....	97

1.0 Organizational Background and Key Contributors

1.1 Primary Points of Contact

Sierra.Jech@nau.edu, Matthew.Bowker@nau.edu

1.2 External Steering Committee Members

Yunge Zhao, Fernando Maestre, Bettina Weber, David Eldridge

1.3 History of CrustNet

Previous networked projects such as SCIN and BIODESERT were inspirations. Informal conversations between Matthew Bowker, Sasha Reed and Fernando Maestre sparked the idea. This led to an informal brainstorming meeting in the Canyonlands between Bowker, Reed, Colin Tucker and Scott Ferrenberg. A biocrust-focused synthesis workgroup funded by the US Geological Survey's John Wesley Powell Center and led by Bowker, Nichole Barger, Jayne Belnap and Anita Antoninka (and including many biocrust researchers from around the world) made a goal of collaborating to craft a study design and sampling protocol for CrustNet. Funded by a Fulbright Global Scholar Award, Bowker drafted the first version of this protocol, obtaining feedback from the JW Powell working group and other interested parties. Bettina Weber and Emilio Rodriguez-Caballero contributed an original study idea for the network. The initial tests of Tier 1 were performed in Iceland at two sites by Bowker. This was followed by tests of both Tier 1 and 2 in Mexico by Bowker, Karen Nuñez, Elisabeth Huber-Sannwald, Victor Reyes Gómez and an amazing support team. This was followed by about 5 years of seeking funding to launch the study. In 2024 we obtained funding from the MPG Ranch Foundation to establish a "mini-CrustNet" in North America and from the National Science Foundation to establish the international network and accept samples and data from many locations. In 2024-5, the PI team crafted the current iteration of the protocol and conducted extensive testing in several sites. **Now, we want you to sample.**

1.4 List of Reviewers

All the following persons either reviewed a version of this protocol, participated in implementing and trialing portions of it, or provided advice that shaped an element of the protocol (alphabetically listed):

Ása Aradottir, Sergio Velasco-Ayuso, Nichole Barger, Jayne Belnap, John Brinda, V. Bala Chaudhary, Theresa Clark, Rebecca Durham, David Eldridge, Akasha Faist, Scott Ferrenberg, Diana Haughland, Carrie Havrilla, Roger Rosentreter, Heather Root, Elisabeth Huber-Sannwald, Kai Schmitt, Steffen Seitz, Fernando Maestre, Bruce McCune, Brett Mishler, Beth Newingham, Oumarou Malam-Issa, Max Mallen-Cooper, Karen Nuñez-Solano, Rory O'Connor, Philip Ramsey, Victor Reyes Gómez, Emilio Rodriguez-Caballero, Katherine Stewart, Ben Sullivan, Bettina Weber, Colin Tucker, Kristina Young, Yunge Zhao,

Yuanming Zhang, Xiaobing Zhou, and six different National Science Foundation (Division of Environmental Biology) panels.

We did not take all of the advice, but we considered and appreciated all input. Any remaining defect is our fault.

2.0 Project Overview

Global sampling and experimentation is far beyond the capabilities of a single research group and will require a joining of forces of many groups and critical stakeholders currently not working together. Resulting data may be pooled for global-scale inference, an element missing from current biocrust research. CrustNet, an array of biocrust observatories (nodes) was designed to answer global-scale questions of interest to scientists, managers and stakeholders, to address the questions:

1. How long do biocrusts require to recover from different types of disturbance, and can this be assisted by human activities?
2. How do biocrusts naturally change through time?
3. What controls biogeography and biodiversity of biocrusts?
4. What ecosystem functions are provided by biocrusts, and how/why does their function change across space and time?
5. Do biocrusts' occurrence accelerate recovery of severely degraded ecosystems?
6. How do biocrusts respond to interannual climate variability and climate change?

In the process of answering these and other questions, we will build a trait database for biocrusts worldwide.

3.0. Mechanics of Operation

3.1 What a Contributor Must Do

To participate in the network, researchers need to commit to select and establish at least one node, survey the node, and provide samples for coordinated analysis. This is Tier 1. Researchers who choose to conduct optional portions of CrustNet (Tier 2 and/or 3, see below for explanation of Tier system) will need to maintain their site for at least 3 years. They must be willing and able to fund their own infrastructure and implementation of the studies in CrustNet, including travel to sites. A contributor will provide soil and other samples to a common lab (Northern Arizona University) for analyses and freely contribute data to a pooled database.

This protocol is divided into a tiered system: Tier 1 requires one-time survey activities, which are designed to be easy and low-cost; Tier 2 requires the establishment of simple, low-cost experiments and repeated monitoring; and Tier 3 requires establishment of experimental infrastructure and voluntary components, which will require greater investment by the contributor in terms of time, labor, or cost.

To participate in the network, researchers must also:

- Pledge to conduct ethical and lawful research. This includes obtaining research permits or landowner consent, where required. This also includes not putting field samplers in dangerous situations, for example requiring field work during extreme temperatures.
- Provide evidence to the Leadership Team that either they have permits or other forms of consent (as applicable), such as pdfs or scans of documents, or provide a statement that no such permits apply, with an explanation.
- Collaborate well with other members of the network. Disrespectful communication and harassment are strictly forbidden.

If a network member fails to abide by these rules, their data will be excluded from the CrustNet database, and their participation in network papers and other science products will be disallowed.

3.2 What a Contributor Will Get (authorship and data usage rules)

The principal investigators and senior personnel of CrustNet are Matthew Bowker, Anita Antoninka, Sasha Reed, Javier Ceja-Navarro, Sierra Gugel, and Anthony Darrouzet-Nardi (we refer to these persons as the Leadership Team). An initial Scientific Steering Committee has been created consisting of the Leadership Team, as well as Fernando Maestre, David Eldridge, Bettina Weber, and Yunge Zhou. Additional members may be added at the discretion of the Committee to add specific expertise, improve international representation, or for other reasons. The role of the Steering Committee is to establish general guidelines for CrustNet, including protocols, data use and timelines, in addition to screening paper ideas from members of the network. All data will be centralized at Northern Arizona University (NAU), and all samples are processed either at NAU or partner groups at the University of Texas at El Paso (UTEP) and the U.S. Geological Survey (USGS). All data will be posted in public repositories such as Figshare, Dryad, or Environmental Data Initiative upon the publication of the articles using them.

The willingness of many scientists to cooperate and collaborate is what makes CrustNet possible. Because this network encompasses a diverse group of people from all over the globe and relies on many data contributors, writing scientific papers can be more challenging than with more traditional projects. Thus, we have attempted to lay out ground rules to establish a fair process for establishing authorship and to be inclusive while not diluting the value of the authorship of a paper. The Steering Committee ensures communication across projects to avoid overlap of papers, works to provide guidance on procedures and authorship guidelines, and serves as the body of last resort for resolution of authorship disputes within CrustNet. The guidelines for co-authorship of the papers arising from CrustNet are described below:

1. By contributing data and samples to Tier 1 of CrustNet according to data submission protocols, two members of each participating group will automatically be included as co-authors on four expected core papers if the group follows deadlines and rules for data submission. The research group may put forward different individuals to author different papers if they so choose.
2. Members from those groups contributing data to optional components of Tiers 2 or 3, will also be co-authors on additional papers arising from each part of the survey they have contributed to (two co-authors per group that has contributed data). We expect 4-5 core papers to arise from Tier 2 components, and 2 core papers to arise from Tier 3 components, assuming there are a sufficient number of participants in these components.
3. In addition to the papers described above, all researchers involved in collecting field data or data processing will be co-authors of a CrustNet “data paper”. This paper will be a “one stop shop” including the whole, raw database gathered during the survey and will be published in an open-access format to maximize the visibility and usability of the data.

4. All the manuscripts derived from CrustNet will be revised by the co-authors before submission; before this the coordinator will contact the responsible person of each participating group, who will provide the names and affiliations of the members of his/her group who should be included as co-authors in each paper.

Data analysis and drafting of the core papers described above will be completed by the Leadership Team, or their designated personnel. In addition, network participants can make proposals to lead additional analyses/articles using CrustNet data. These proposals will be submitted to the Leadership team and reviewed by the Steering Committee (including title, abstract and potential list of co-authors/nodes when doing so and list of CrustNet datasets used), who will discuss and review them to ensure there is sufficient distinction from proposed and ongoing/planned CrustNet papers. The Steering Committee may suggest altering or combining analyses and papers to resolve issues of overlap, as well as recommendations for including co-authors who could help with the data analysis and writing or who have substantially contributed to the generation of the data used in each paper. If there are no overlaps between a proposal for a new manuscript and other ongoing/planned manuscripts, the Steering Committee will approve the proposal and will provide the lead author with the data needed to conduct the analyses. If a manuscript is proposed and subsequently abandoned for more than 10 months, the Steering Committee reserves the right to contact other interested CrustNet participants and discuss taking over the development of the manuscript with the original lead author.

In addition to the papers that can be obtained from the analyses of the whole network data, we also encourage papers based on a subset of network data. Authors interested in leading analyses with subsets of the data should send a proposal to the Steering Committee (including title, abstract and potential list of co-authors when doing so and list of CrustNet datasets used). If there are no overlaps or compromise of novelty between a proposal for a new manuscript using a subset of data and other ongoing/planned manuscripts, the Steering Committee will approve the proposal and will provide the lead author with the data needed for conducting the analyses.

Finally, any participant is free to use the CrustNet data obtained from their plots for publication purposes, presentations, courses and other non-published venues (e.g., blog posts, scientific meetings, proposals). For this, there is no need to obtain approval by the Steering Committee, although data that are not those directly gathered by each group at their sites should be requested from the coordinator.

3.3 Selecting a Node

We seek nodes in distinct ecoregions that support biocrusts, including drylands, alpine areas, polar areas, and other regions. In most nodes, biocrusts will be a part of a late seral stage, but successional biocrusts can also be considered, if they can reasonably be expected to persist for the sampling period (examples include post-glacial biocrusts, restored biocrusts, or early seral forest biocrusts).

A given research group is encouraged to sample more than one node (up to five), but we ask that they be located in ecological distinct settings from other nodes. More than one node can and should occur in the same ecoregion (e.g., the Chihuahuan Desert or Colorado Plateau), but with additional nodes we should also strive to be geographically, climatically, and/or edaphically distinct. For example, multiple nodes could occur along the long N-S axis of the Chihuahuan Desert, or nearby each other on very distinct soils in the Loess Plateau. It is preferred that all nodes are spatially discrete (at least 10 km apart). An exception to this can be made if **ALL** of the following are true: suitable sampling areas are scarce, and two strongly different soils (e.g., gypsiferous and sandy) occur in the same location, and distinct biocrusts occur on the two soils. If these conditions are met, two nodes (each representing a different soil type) may be established within the same general location. The overarching goal is that each node be different in some key way. A current list and map of pledged or existing nodes and brief descriptions is maintained at this link: crustnet.org/nodes to help prospective samplers decide where to place their nodes.

Network nodes would need these qualities:

1. Return visits must be logistically feasible (Tier 2 and 3 only)
2. Low likelihood of vandalism or theft (Tier 2 & 3 only)
3. Reasonable protection against chronic disturbance (especially for Tier 2 and 3)
4. Landowner's / user's /agency **approval and/or permission** to conduct research. The CrustNet Leadership Team can provide examples of approved permits and text that might be useful for requesting permits. Please reach out if this would be useful for your node.
5. Substantial biocrust cover (at least **10%** across the whole node, with at least some high cover patches). In most systems, biocrusts should be present at or near their potential (a late-seral well-developed state), usually indicative of low disturbance. In some cases, the biocrusts will be a temporary part of the succession of an ecosystem; these may also be included but cover should be substantial, and the cover would be expected to persist over the 3-year life of the project.

Preferable network nodes will also have these qualities:

1. Fencing or a lack of uncontrolled livestock disturbance. Typical levels of native wildlife disturbance are acceptable.
2. Road access to facilitate low-cost sampling and monitoring.
3. Representativeness of a particular ecoregion (e.g., the Atacama Desert) **OR** desirable uniqueness (e.g., human-induced biocrusts on andisols of Iceland).
4. Synergy with locations that have an existing history of science (e.g., LTER, CZO, LTAR, TERN, etc.), including meteorological monitoring.
5. Knowledge of land use history.

A node must accommodate a representative 30 m radius circular area (2827 m²), several dozen quadrats (0.25 m x 0.25 m to 0.5 m x 0.5 m; some permanent if Tier 2), and optional experimental infrastructure such as biocrust transplants or rainfall reduction shelters (if Tier 3). Thus, we recommend an area of at least 1 ha. For logistical reasons, relatively flat sites are preferred, but sloping sites may be included.

4.0 Survey and Sampling Methods (All Tiers)

4.1 Timing of Sampling

The timing of sampling is intentionally flexible and depends partly on which CrustNet components are being done. Some best practices are listed below:

1. Tier 1 sampling is best conducted outside of peak annual plant biomass to facilitate better visibility of biocrusts and avoid confusing functional effects of biocrusts and annual plants.
2. It is also advisable to visit sites when dry (in between rain events) to reduce the need to dry soils later and eliminate soil measurement variability.
3. One Tier 2 component (the disturbance-recovery experiment) includes inoculation of plots with biocrust material. This component is ideally performed just before or during a less stressful time of the year, which is more likely to be the most active growing season for biocrusts. This will differ in different places, and the Leadership Team can help decide when to conduct this portion of the study. It may be convenient to sample or establish different tiers of CrustNet at the same time, but this is not strictly required.

We understand that for various reasons it may be impossible to follow all of these best practices simultaneously. If you must deviate from some of them to enable you to participate in CrustNet, we still encourage your participation.

4.2 Pre-sampling

Become familiar with biocrust communities present and develop a classification system for cyanobacterial or algal biocrusts. Samplers must fully characterize the biocrust cover and community structure in the various surveys and experiments within CrustNet. All elements will apply the same approach.

For mosses, bryophytes, lichens, and macrocolonies of cyanobacteria (e.g., *Nostoc commune*), we will identify to the species level to the best of our ability. For practical reasons, we cannot key every specimen of every taxon centrally, therefore we are relying upon samplers to become familiar enough with their biocrusts to collect data with a high taxonomic resolution. Our operating principle is that if a taxon can be visually distinguished from others *in the field, based on characters observable in the field* then it should be distinguished from other taxa in percentage coverage data. We accept that sometimes groups of look-alike species cannot be distinguished reliably, and that they may need to be treated as one type (lumped) when collecting percentage cover data or conducting a biodiversity survey or trait collection. In such cases, we ask that surveyors use pseudonyms. A pseudonym is an operational, unique and invented name for something that can be used until the true name is known. When using pseudonyms, strive for genus-level, for example, *Bryum 2*, but if you are unable to identify the genus, develop a unique pseudonym that is descriptive (e.g., unknown brown squamulose lichen).

If you are unfamiliar with how to visually distinguish different species of mosses, lichens, or liverworts, or what characters to focus on, please view our videos first: dirtlab.weebly.com/resources. A hand lens or other type of magnifier (magnifying glass, smart phone macro-lens) will be an essential tool for samplers. In order to help anticipate which biocrust species you might encounter, you may also take some of the following steps:

1. Search for previous biocrust literature in nearby areas to obtain species lists which may help narrow down the possibilities for you.
2. Contact regional experts for some guidance about the likely species compositions.
3. Consult online herbarium records to generate lists of species (this will be even more helpful for vascular plants).

If possible, advance reconnaissance visits to your sites can be very helpful in learning the biocrust communities but are not strictly necessary. Even if an advance visit is not possible, spending some time when you first visit a site, but before actually conducting sampling, can be very helpful (a note to be careful to minimize disturbance as you learn the taxa). Best practices might include making an initial collection of a few specimens of what appear to be the most common taxa. Verify that the specimens resemble other specimens of the same putative taxon but are distinguishable from specimens of other putative taxa. Initially it is better to err on the side of “splitting” rather than “lumping”; for example, if you find two visually consistent forms that may or may not be the same species, treat them as if they are separate species in your data collection. If it is learned

later that they are the same species, the data can be combined (lumped), but if the data are lumped initially, there is no way to separate (split) them later. Use the knowledge within your group to tentatively identify your specimens; if they cannot be identified, develop pseudonyms that you will use in your data collection, and short codes for them that you will employ in your datasheets. As you conduct the surveys in CrustNet, you may encounter more taxa than were captured in your exploratory collection. If you can identify them, do so in your datasheets, otherwise develop new unique pseudonyms for each species encountered. When your work is complete, you may have a few to many taxa still unidentified. These will have to be determined later. Best practices would include vouchering unknown taxa by bringing back a few specimens of the unknown biocrust from the field (well-packaged and protected), and also high-quality photos (well-focused with sufficient lighting, using a macrolens in some cases) to aid later identification.

Best practice for photos would be to attempt to capture:

- General appearance of lichen or bryophyte clump/colony
- The microenvironment and general macroenvironment
- The general appearance of individual stems within the colony (if applicable, e.g., mosses)
- The wet and dry state (especially mosses and liverworts)
- Closeups of any feature that seems to distinguish the putative taxon from other taxa (e.g., awns on moss leaves, podetia, or soredia on a lichen)
- Closeups of any possible reproductive structure (sporophytes, gemmae cups, Apothecia or perithecia, etc.)
- Any potentially diagnostic images from later laboratory examinations (e.g., leaf slides for mosses, chemical spot tests for lichens)

To obtain identifications of unknowns will require a combination of the following:

1. Keying specimens using appropriate regional keys if you have the requisite experience
2. Consulting regional lichen and bryophyte taxonomic experts for help with identification
3. Crowd-source your identification to the CrustNet project within iNaturalist.

iNaturalist is a free application that can be downloaded either to a phone or computer. Users need to create an account. Once created and logged in, users can enter “CrustNet” in the search bar, or navigate to <https://www.inaturalist.org/projects/crustnet-global-biocrust-research-network-2be0621d-25c7-405d-87bf-d816ae378d11>. Once at the project page, users can post observations using the red “add observations” button. Observations will include photos, location data, the three-letter node code, and the growth substrate (i.e., soil). Other users will post possible identifications, and tips to help you confirm identifications. It is advisable to include as much information as possible that might help others identify a specimen. Users of the iNaturalist project are other samplers

or members of the Leadership Team in addition to selected taxonomic experts who will participate in CrustNet through iNaturalist consultation. If none of the three identification options is available to you, please contact the Leadership Team for advice.

If cyanobacterial or algal biocrusts are a component in the node, field identification of species is simply not possible in most cases. In such cases, estimation of the cover of different cyanobacterial-algal biocrust community types **is** possible. If you are new to cyanobacterial biocrusts, please view our video at dirtlab.weebly.com/resources, coming soon. Determine the efficacy of a default categorical system describing the level of development using three categories:

1. Dark cyanobacterial crusts
2. Light cyanobacterial crusts (**Figure 1**, the dark and light refer to level of dark pigmentation)
3. Uncrusted bare ground

Your assessment of efficacy should be based on your observation of the biocrust at your site, and your expert opinion. These default groupings are extensively documented in the literature around the world in drylands supporting cyanobacterial crusts. Dark cyanobacterial biocrusts are often more successional advanced, developed, and functional; light crusts tend to be an earlier successional sere but are still a clearly aggregated biocrust; uncrusted bare ground is self-explanatory and not aggregated by biota.

- *Dark cyanobacterial crust:* Majority of biocrust surface is nearly continuously covered by surface bound, darkly pigmented cyanobacteria (e.g. *Nostoc*, *Scytonema*) growing over a stable platform engineered by filamentous cyanobacteria (e.g. *Microcoleus*); color is gray to black.
- *Light cyanobacterial crust:* Biocrust surface is clearly aggregated; if a subsample is examined more closely and broken in the hand, filaments can be detected in the biocrust signifying a major effect of biota on aggregation. It is possible to lift intact pieces of the biocrust away from the soil surface with a finger or a tool such as a pocketknife. Color is approximately the same as underlying soil but may green up when wet. Often, a light cyanobacterial crust will have a different visually apparent texture or micromorphology than bare ground (for example, light cyanobacterial biocrusts may have rugose or pinnacled surfaces while bare ground has less or no such texture). Since light cyanobacterial crusts can be cryptic, it is allowable to prod the soil surface with a pin flag to verify that the soil is well aggregated and/or that filaments are visually detectable. However, in permanent monitoring plots, please do so in a way that minimizes creating disturbance that might affect data later.
- *Bare ground:* No visual evidence of biocrust formation. Soil surface may or may not be aggregated/cohesive. If a subsample is examined more closely and broken in the hand, either no filaments at all or only very few filaments will be seen; the number of filaments present (if any) is insufficient to lead to

biologically generated aggregation. It may or may not be possible to lift intact pieces of the soil surface away with a finger or a tool, rather soil may easily fragment into particles or small aggregates. Soil does not green up when wet. Color of surface soil is identical to underlying soil.

If this default system does not capture the development of the biocrusts at the site (e.g., you might encounter green algal dominated biocrusts), surveyors should develop their own 2-3 level system and document each level or category in high resolution photos and document a verbal description of each. The verbal description should focus on what *can be seen* (document degree of aggregation, color relative to subsurface, whether filaments are visible in a broken crust, whether perceived dominant is algal or cyanobacterial).

Finally, familiarize yourself with the soil sampling and functional measurement procedures. The videos that can be found at crustnet.org/videos demonstrate these procedures. In particular, the soil aggregate stability test requires preparation to be familiar with the timing requirements and the category system for the stability classes.

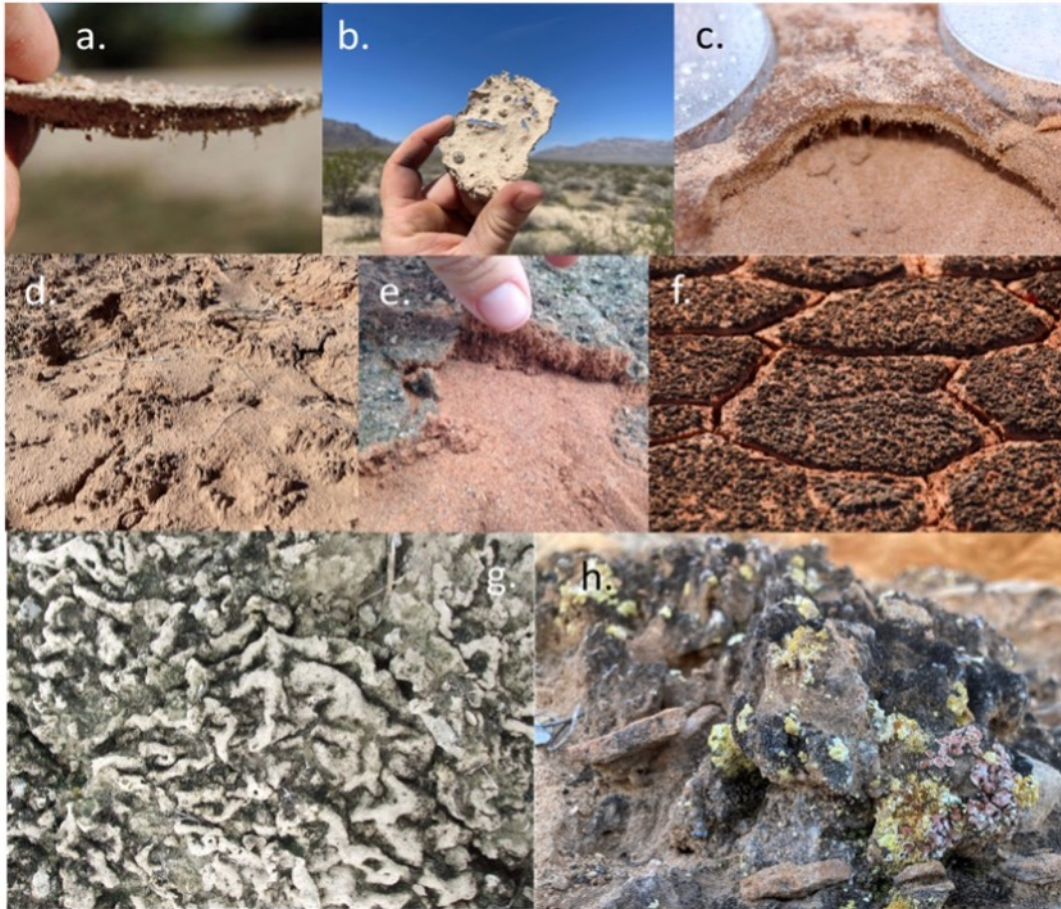

Figure 1. Distinguishing bare ground and light and dark cyanobacterially dominated biocrusts. Light cyanobacterial biocrusts have the same color as underlying soil but are clearly aggregated at the surface (top few mm to 1 cm) (a,b) such that a piece of the biocrust can often be removed from the surface and hold its shape. In a light cyanobacterial crust, close inspection along a breakage point or along the underside of a biocrust piece will reveal cyanobacterial filaments, usually appearing white or tinged with green (a,c). In some regions, light cyanobacterial biocrusts may have distinctive surface textures or roughening patterns that appear different from bare uncolonized soil (d). A dark cyanobacterial crust is distinguishable from light cyanobacterial biocrust by the presence of gray to black pigmentation or discontinuous dark speckling of the biocrusts at the very surface, rendering it a different, darker color than underlying soil (e). The dark pigmentation can be intense, and nearly continuous, rendering a biocrust mostly black (f). Dark biocrusts may exhibit a variety of textures that vary from region to region, including flat (**Figure 5e**) cracking (f), wrinkling (g) or pinnacle formation (h). It is common for a patch of biocrust to be a mosaic of different types, rather than being formed of a single type. Examples include few, scattered lichens over a matrix of light cyanobacterial crust (b), finely intermingled light cyanobacterial biocrusts atop microridges, and dark cyanobacterial biocrusts within microvalleys (g), and intermixed patches of dark and light cyanobacterial biocrusts and various lichen taxa (h).

4.3 Voucher Specimens

As mentioned above, it may be necessary to bring unknown specimens of either biocrust or plants back from the site for laboratory identification, or to show them to a specialist. This is true for any components of CrustNet that require species-level identifications. With regard to biocrusts, it is crucial to keep the specimens intact and well-preserved. **Many specimens are fragile.** If the specimen is growing on a very fragile soil, gentle moistening (e.g., with a spray bottle) can help you remove a sample intact from the soil surface. For maximal protection of the most fragile specimens, they can be placed into petri dishes with locking lids. Adding tissue paper or cotton balls inside the dish will prevent shaking and collision with the dish. If moist samples are sealed within petri dishes, they must not remain sealed in the wet state, or they will mold. Thus, they should be opened and air-dried at the earliest convenience, when they are in a safe place. Coin envelopes are a good option for somewhat less fragile specimens. The specimen can be placed inside, wet or dry. If wet, drying can occur within the coin envelopes, as long as they are not sealed within an impermeable bag. Both petri dishes and coin envelopes are conducive to labeling an individual specimen. Record any pseudonym that you use for the species in the datasheets, and as appropriate the specific study, sample unit and node name, so that it can be linked later to your data. If specimens are not fragile, or if you have difficulty obtaining the materials above, specimens can often be protected by wrapping them in tissue paper and placing them inside a plastic box with a lid that snaps shut. If this method is used, we recommend using a small piece of tape to make a brief label for each individual specimen, and a list of specimens inside the box that lists all of the brief labels along with any additional information about that specimen (pseudonyms, specific study, sample unit, node, notes, etc.). With any specimens, the very first one you encounter may not be the best for displaying diagnostic characteristics. It can be useful to also collect additional specimens suspected to be of the same unknown taxon, especially if they display useful characters for identifications (e.g., reproductive structures).

In summary, **do** take extra care to protect specimens from crushing or shaking. **Do** moisten specimens if it helps you obtain more intact ones or keep them intact until they get to a safe place. **Do** practice good labeling and linkage of the specimen to your data. **Do** collect extra specimens if they help display characters that the original specimen does not. **Don't** leave wet specimens sealed in plastic bags or containers, they will rot.

You may also need voucher specimens of vascular plants for some portions of the study that require species-level plant data. These are less fragile and can be placed within paper bags, labeled with the same identifying information as listed above pseudonyms, specific study, sample unit, node, notes, etc.). Strive to include healthy specimens in your collection, and include flowers, cones or fruit if they are present.

4.4 Soil Sampling & Handling General Overview

Multiple components of CrustNet require samplers to obtain soil samples. Though the specific instructions may vary based upon the specific part of the protocol being performed, some general principles apply:

- Principle 1. One or two depths may be sampled in various CrustNet components. 0-1 cm samples will be taken in all cases. In some cases, additional 1-5 cm samples will be taken.
- Principle 2. Samplers will often be instructed to create a composite sample. A composite is created when multiple samples are pooled together into one composite sample representing either the node or a plot. We provide instructions regarding the desired minimum amount of sampled soil, and minimum number of samples per composite sample.
- Principle 3. Soil collecting implements and methods may be modified to better match conditions at your site, and materials available to you, as long as they meet the goals of accurately sampling to the prescribed depth.
- Principle 4. In the specific project components, instructions will be given about specifically where to obtain soil along a transect or within a plot. If needed, samplers may alter the specific sampling locations to avoid anomalous sampling conditions (e.g., a large stone, or an animal burrow), to preserve the representativeness of the sample.
- Principle 5. Labeling sample bags. When possible, please write on the white labeling area of a Ziploc or Whirlpak with permanent pen (e.g., Sharpie). In addition, please consider redundantly labeling the bags by including labels written on paper in each bag. We can provide these paper redundant labels for you upon request.
- Principle 6. To obtain 0-1 cm samples, the default sampling method will be scraping. Scraping is the process of using a flat-bladed hand tool to insert parallel to the soil surface at a 1 cm depth on average and lifting away the surface soil for collection. A target surface area will be provided, and researchers should strive to sample the requested surface area so that some measurements can be expressed on an areal basis (**Figure 2**). A variety of masonry tools, plumbing tools, painting and construction tools may be suitable, and samplers are free to choose tools available in their area (**Figure 2**). Please watch our video on soil sampling for a demonstration (<https://crustnet.org/videos.html>). In all cases, a 0-1 cm sample includes any above ground biocrust tissue (e.g., mosses, lichens), in addition to the uppermost 0 - 1 cm of underlying soil. Tissues of biocrust biota will be treated as part of the sample. In the event that scraping is ineffective at a site, samplers are free to implement their own “tried & true” methods for obtaining 0-1 cm samples but must sample at least the specified surface area of soil, and document the areas sampled if it is different from the requested area.

- Principle 7. In cases where an additional 1-5 cm sample is requested, the best practice is to sample sequentially. For example, you may first be instructed to scrape a 5×5 cm area to obtain a 0-1 cm sample. Then, within the scraped area, you would obtain your 1-5 cm core sample, as the 1 cm depth would now be at the top of the soil following the 0-1 cm removal from the first sampling.
- Principle 8. In most cases, soil coring devices with a diameter of 1.5 cm to 2.5 cm will work well (**Figure 2**), but the *diameter or cross-sectional area used must be documented, along with the number of samples collected and combined to create a composite sample*. Occasionally, stony soils or other factors may require an alternative diameter or technique. If samplers have not sampled soil at their site before, we recommend being prepared with multiple soil coring options. Purchased T-shaped corers (**Figure 2**) are often useful, but samplers are free to make their own low-cost coring devices. Coring devices can often be made from lab supplies such as plastic vials or centrifuge tubes (**Figure 2**) and should usually be inserted in soil using hand pressure. Some soils may require more sturdy corers that can be hammered in, such as metal cylinders or bevelled PVC pipe. Cores need not be circular in cross-section, other materials with square or rectangular cross-sections may also be useful. Please watch our video on soil sampling for a demonstration (<https://crustnet.org/videos.html>).

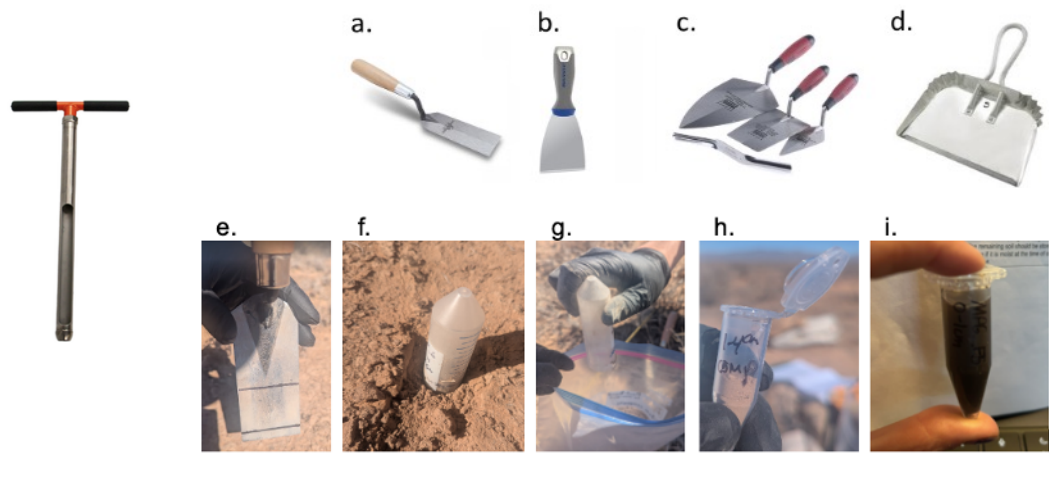

Figure 2. Soil sampling equipment. **a-d.** Useful flat bottomed soil sampling tools referred to in this document. **a.** flooring margin trowel (common sizes include ~12.5 cm length x variable widths); **b.** paint scraper/putty knife; **c.** masonry or brick trowels (variable styles and sizes); **d.** construction-grade dustpan (useful for scraping larger surfaces such as in some optional components of Tier 2). **e.** Soil probe rod with T handle for obtaining a 1-5 cm sample. **f.** Example of useful markings on margin trowel to guide 1-cm-depth and 5-cm-on-a-side scrape samples. **g-h.** Example of an improvised sampling device (in this case 50 ml Falcon tube) for the 1-5 cm sample taken under the scraped section. Other sampling devices can be used depending on soil characteristics at a given site. **h.** Example of empty labeled 5-ml centrifuge tube (provided in sampling kits) before addition of soil and RNA later. **i.** After filling with soil and RNA later.

- Principle 9. For any samples designated for molecular genetic analysis, samplers will be asked to separate a subsample from the larger sample and apply a chemical treatment for RNA preservation. To separate a subsample, first mix your entire sample within its collection bag alternating gentle shaking and rotation, with pressure between your fingers to break apart aggregates and biocrust pieces. We recommend 1 quart or 1 L size self-sealing bags (e.g., Ziploc brand, widely available for food storage); freezer grade bags are thicker and thus preferable. **Do not** place your fingers *inside* the bag (to avoid contamination), rather apply pressure to the exterior of the bag to break the aggregates within. When you no longer detect aggregates larger than about 0.5 cm in diameter, the sample has been sufficiently disaggregated. Then, open the bag and repeatedly obtain small subsamples using a small spoon, spatula, or other sampling tool (recommended volume per subsample = 0.25-0.5 mL) that has been sterilized (see below) and place them into the provided 5 mL tube (**Figure 2**), filling it halfway. To do so, draw soil from multiple areas (at least 5) in the bag, avoiding rocks, gravel and large pieces of organic debris. This process will help to avoid bias and better represent the entire soil sample. Sterilize your sampling tool with 70 % ethanol or isopropanol prior to subsampling, then again before processing the next sample. An alternative method is to disaggregate the sample, pour it into a container such as a bowl or plastic food container, and conduct the subsampling from that container, then pouring the remaining contents of the container back into the sample bag. This method will require cleaning of the bowl with 70 % ethanol or isopropanol before processing the next sample. This soil sample in the 5 mL eppendorf-style tube will be used for molecular analyses. You will be provided with RNAlater solution. Add the provided RNAlater solution to the soil in the tube until the sample is fully submerged. This should be performed before leaving the field site. Please keep these samples in a cooler or other insulated container until they can be returned to the lab, to protect from extreme temperatures and fluctuations. Label each tube in Sharpie with a unique 1–2-digit number. Then redundantly label the sample with the full sample name (Node Lead_Three Letter Node Code_Plot Name_date) on the side of the tube. Detailed information about Plot Names can be found in **Appendix 6**. There is a datasheet to record the unique sample ID that you assigned to the tube and the full sample name. This datasheet should be submitted with the rest of your datasheets. The remaining soil should be air dried in a shaded or dark location if it was moist at the time of collection. When the sample is air dry, it should be sealed for transport.
- Principle 10. To collect cores for nitrogen fixation and/or carbon fixation, first, moisten the soil to be sampled with a spray bottle to facilitate obtaining an intact core. Press the corer into the soil with hand pressure, gently tapping with a rubber mallet only if you must. The cores should be ~ 1 cm deep. The 1 cm depth refers to the uppermost cm of mineral soil (focusing on biocrust); in some cases, biocrust mosses or lichens may grow above the soil surface (indicated by mineral matter). In such cases, collect the organisms in addition to 1 cm of soil below them. After obtaining the core, push a Kimwipe, toilet paper, or something equivalent under the sample and then seal the

bottom of the tube with one of the provided rubber stoppers by pushing and twisting the rubber stopper tightly into the tube. We recommend storing the cores upright in the tubes until they can be air-dried and sealed. Air dry them at the first opportunity once in a safe location (no later than 24 hours after collection). Let the samples sit on a benchtop or desk to allow them to air dry prior to mailing them (a few days of drying should be enough). If you are having trouble drying, please contact us. Once the samples seem dry, insert Kimwipes, toilet paper or something equivalent into the tops of the tubes to hold the sample in place and reduce movement during shipping. Add this cushioning material to the top of the tube as needed and then seal the top with another rubber stopper. Follow the instructions in **Appendix 10** to package the samples for shipping.

- Principle 11. **Appendix 10** includes instructions about how you should send all soil samples to Northern Arizona University (NAU). Follow the instructions carefully!

4.5 Minimizing Your Impact - Overview

Many biocrusts are fragile and can easily be destroyed by trampling. The presence of researchers conducting data collection and sampling will impact the site, but participants should strive to reduce the damage caused by their presence. Some suggested practices are listed below.

- Restrict the areas in which surveyors walk.

Some strategies recommended by participants include establishment of access paths, establishing a “gear drop” location at plot center, sampling on a standardized side of transects and quadrats, avoid having multiple people walk the site to select plot placement (this task can be done one or 2 people), reducing the movement of persons recording data for others (e.g., having them remain stationary nearby, preferably in a designated disturbed area). You may apply your own strategies that you know are effective at your site.

- Reduce the severity of disturbance in areas that are incidentally disturbed.

Some strategies recommended by participants include wearing soft-soled shoes rather than hard soled boots (if safe to do so), use flat pieces of foam as kneepads to disperse weight when surveying quadrats or transects, protect high-traffic areas such as the gear drop zone or portions of the access path with cushioning materials (e.g., pieces of old carpet, rugs). You may apply your own strategies that you know are effective at your site.

- Avoid disturbing the best developed biocrust patches.

Biocrust coverage and development is often patchy. It is usually possible to find walking paths that avoid the best developed patches.

5.0 Sampling Instructions

5.1 Site Characterization (mandatory for all Tiers 1-3)

1. Establish standard walking paths at the node. Upon arriving at the node be extremely careful to minimize unnecessary trampling in the plot and surrounding area, and to concentrate necessary disturbance to only a few designated areas, especially if you plan to conduct Tier 2 or 3 sampling. As the various plots and quadrats are placed, we recommend that you establish a standard walking path that workers may use during sampling or when they need to revisit the plot. It can be permanently marked with rocks and other objects and clearly marked with pin flags during site visits. The walking path should avoid well developed biocrust patches (because they may be useful in other elements of CrustNet sampling), and it should avoid the line-point intercept transects to be placed (below).
2. Choose a location for the center of the Community Structure survey (**Figure 3, Tier 1 Community Structure Survey**). In many cases the approximate center of the ~1 ha node area will be a good choice, but it can be at any location in which the spokes will be contained within the node area.
3. Include the name of the person who is responsible for the node as the Node Lead.

Record the following in the site metadata spreadsheet:

4. The center point of the spoke transects using GPS (lat/long; WGS84). Include the GPS accuracy when the point was taken.
5. Slope and aspect of the node with a clinometer and compass; if the node is topographically simple, conduct one measurement at the node center. If topography is complex, strive to capture the prevailing slope-aspect of the whole node from 2 or 3 locations (we can attempt to verify slope measurements later using digital elevation models). Report the 2 or 3 measurements in the datasheet. Also note whether the slope is simple, convex or concave, whether the degree of variability is simple or hilly/dissected, and whether the landscape position is a lowland, upland or mid-slope. If a digital elevation model (DEM) is available for the site, it is also suitable to digitally calculate these numbers.
6. If soil type is known, identify it and your source for this information. The preferred soil classification is the reference soil group using the WRB system ([World reference base for soil resources 2006.pdf](#)). If the soil type in the WRB system is unknown, but it is known in another system, please identify the soil classification system used and the soil to the most specific level in the alternative system (example: providing order, suborder, great group, subgroup, family and series in USDA Soil taxonomy [Soil Taxonomy.pdf](#)). In general, soil classification systems used in multiple nations such as WRB or USDA Soil Taxonomy are preferred over strictly national systems. Note: it is not necessary to dig a soil pit.

7. If soil parent material is visible, identify it to the degree possible (examples: Quaternary Alluvium, Entrada Sandstone, etc.), otherwise take photographs and/or consult with geologists or geological maps of the region.
8. Obtain the most visually appealing images of your study system that you can, both of the landscape and the organisms within it; these may be useful later in publications to highlight the diversity of ecosystems sampled.
9. Make a visual estimate of vegetation cover (canopy cover) by scanning the node in all directions from the center, using a cover class system (0, 0-1, 2-5, 6-15, 16-30, 31-50, 51-75, 76-100). Do so for major functional groups present: trees, shrubs, cacti/succulents, forbs, graminoids, vascular cryptogam (e.g., *Selaginella densa*). Record the most dominant plant species overall in rank order of abundance, indicating nativeness and growth form. List between 2 - 5 species, as appropriate to characterize the plant community of your site. If an exotic species is not among the listed dominants, also list the most abundant exotic species (if one is present and detected). Fill out all site characterization information in the provided datasheet templates.

5.2 Tier 1

Tier 1 consists of one-time surveying and sampling activities. Our goal is to exceed 75 Tier 1 nodes, though 50 nodes will be considered adequate.

Tier 1 will:

1. Measure cover and diversity patterns of biocrusts
2. Determine spatial co-occurrence patterns of plants and biocrusts
3. Evaluate the relationship between biocrust community structure and function
4. Create a global biocrust trait database.

All elements of Tier 1 sampling are mandatory for CrustNet participants.

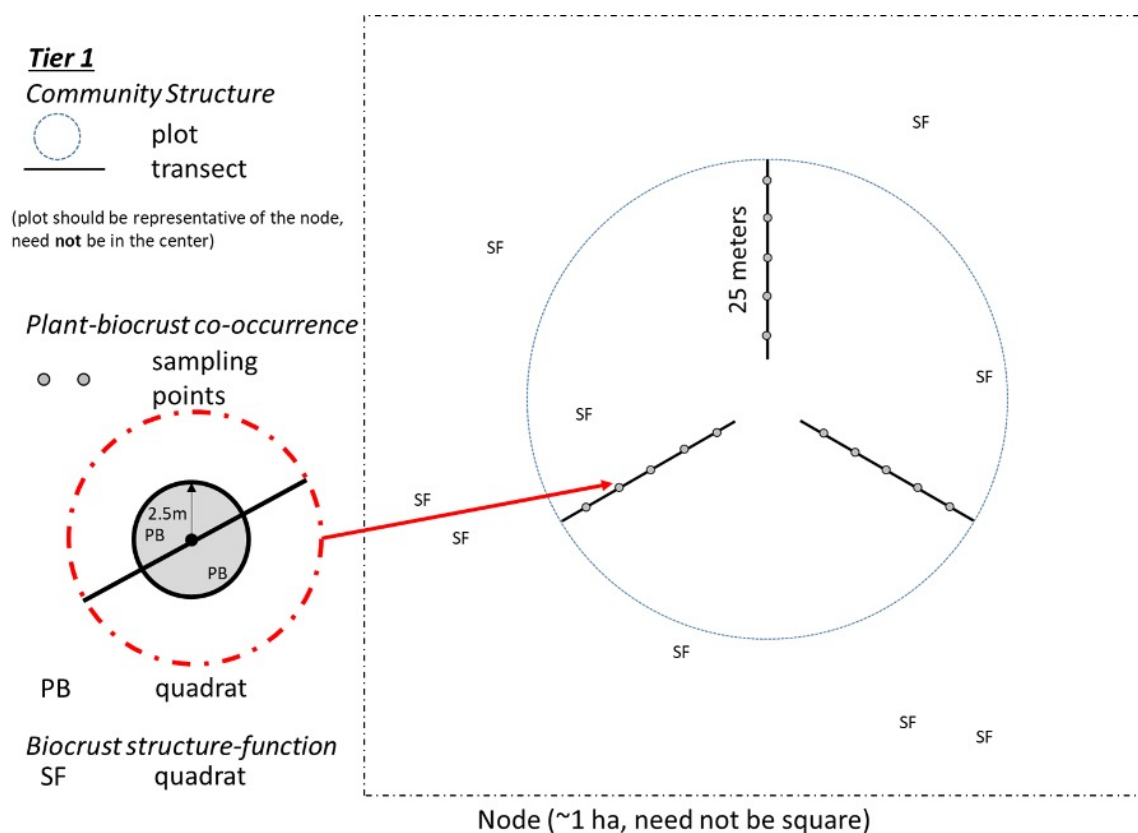

Figure 3. Overall schematic of a theoretical node and Tier 1 components. Some components/activities are not shown because they are distributed collections across the whole node (Biodiversity Survey, Trait Database), rather than being isolated to quadrats or transects. All pictured quadrats (SF or PB) are 25 x 25 cm. Tier 1 includes a total of 40 quadrats, each sampled once.

Tier 1. Community structure survey.

(This portion of the protocol will require surveyors to distinguish between different taxa and types of biocrusts. Please review the previous section for guidance: *All tiers. Pre-sampling: become familiar with biocrust communities present and develop a classification system for cyanobacterial or algal biocrusts.*)

10. Select a 30 m radius circular plot representative of the node, to be surveyed once. Mark the center with a wooden stake or other temporary, but visible, monument; the center will be one of the designated areas in which workers can disturb the surface and which will be exempted from sampling. Record GPS coordinates of the center of the plot (lat/long; decimal degree, WGS84).
11. Radiating out from the center marker, establish 25m spoke transects extending to the plot margin (30m) at 0°, 120°, and 240°N (**Figure 3**). These transects should begin 5m distant from the plot center, leaving the plot center (a 5m radius circle) as an unsampled area. If necessary to avoid anomalous areas of the node (or infrastructure of other studies), this entire configuration can be rotated (preferred solution; e.g. 10°, 130° and 250°N), or if needed, an individual transect can be placed along a different bearing as long as it is not within 60° of any other transect (e.g. 0°, 120°, and 200°N). If you do not believe a circular plot like this will be possible to place at your site, please contact us for recommendations.
12. Take a high resolution, digital photo at the beginning of each transect looking toward the plot margin (outward view). In each photo, include a placard (small dry erase board), which identifies the plot, the transect, and the viewpoint (inward, outward). Do not include people or equipment in the photo.
13. Survey the transects.
 - We recommend that only one surveyor walks in the plot to minimize disturbance; walk on the left-hand side of the transect tape while surveying on the right-hand side. Data recorders should remain away from the transect. Fill out the provided datasheet templates with line-point intercept data.
 - Beginning 5 m away from the plot center, conduct a line-point intercept survey and sample every 20 cm for a total of 125 points per transect. This method is derived from Herrick et al. 2017, with minor modifications in the ground layer data. Lower a pin flag vertically at each sample point, so that it is touching the right-hand edge of the tape. Perform a “controlled drop” until the pin flag makes contact with the ground surface. Record the uppermost plant species encountered at the point, if any (**Figure 4**).
 - If no leaf, stem or plant base is intercepted or touches the pin, record “N” for none in the “Top layer” column of the data template.

- If there are tall shrubs or trees present, the surveyor may have to mentally extend the pinflag upward or use a laser to determine if a much taller pin flag would have intercepted the canopy. Record all additional species intercepted by the pin, in the order that they are intercepted, from top to bottom (record each species only once, even if it intercepts the point more than once).
- If a plant species is not known, use the following codes, adding sequential numbers as necessary: AF# = Annual forb (also includes biennials) PF# = Perennial forb AG#= Annual graminoid PG#= Perennial graminoid SH#= Shrub TR#= Tree. If necessary, collect a sample of unknown plants off the transect for later identification.
- At the ground surface, record the following categories if present:

Ground surface categories	Description	Example code for datasheets
Leaf litter	detached stems, roots, leaves, and leaves	LEAF
Woody debris	detached woody or succulent litter that is greater than 5 mm in diameter	WOOD
Duff	partially decomposed plant matter	DUFF
Dung or scat	Animal dung or scat	SCAT
Animal matter	Decomposing animal remains (e.g., carcass, bones, etc.)	ANMAT
Inorganic litter	Plastic, metal	INORG
Vagrant lichen	do not record as crust, do identify species	VAGRLIC
Rock lichen	do not record as biocrust, species identification not needed	ROCKLIC
Gravel	5 - 76 mm	GRAV
Cobble	>76 – 250 mm	COBB
Stone	250 – 600 mm	STONE
Boulder	>600 mm	BOULD
Bedrock	Exposure of bedrock of any size	BEDR
Eolian Sand	Recently deposited	SAND
Animal digging	Burrows, forage pits	ANDIG
Animal trampling	Hoof print	ANTRP

- If needed, additional categories can be created with full documentation of the meaning. For example: In one site, dead, decomposing bases of bunchgrasses were abundant and important habitat for biocrust organisms. It seemed important to distinguish this type of surface cover from the other litter and duff categories by adding a new category (e.g., DUFF2).

- If none of the above ground surfaces are encountered, please record bare ground, light cyanobacterial crust, dark cyanobacterial crust, or the species of moss, liverwort or lichen intercepted. If the default classification of cyanobacterial-algal crusts did not apply at your node, replace with the system you developed and documented.
- There is usually only one ground surface intercept, but there may be more. This occurs in two situations (one over the other, or multiple adjacent). Some types of ground cover (thin, e.g., < 2 mm, or discontinuous deposits of leaf litter, thin recent deposits of eolian sand, woody debris that does not contact the soil surface at the interception point, vagrant lichens) may also have another kind of ground cover underneath them. If a type of biocrust is underneath, it should be recorded as an additional hit for that point in the soil 2 column (example: litter overtopped *Syntrichia ruralis*, litter was recorded in the Soil Surf column, *S. ruralis* was recorded in the Soil 2 column). If no type of biocrust is underneath the ground cover in question, an additional soil 2 hit should not be recorded. Occasionally a pin will intercept the meeting point between two adjacent biocrust species or types. In this case, record both, adding one of the taxa to the Soil Surf column and the other to Soil 2 (order is unimportant). (example: point intercepted the boundary between *S. ruralis* and *Cladonia pocillum*, touching both, **either** *S. ruralis* or *Cladonia* is recorded in the Soil Surf column and the other is recorded in the Soil 2 column) If more than two are intercepted (this should be quite rare), record the 2 intercepted taxa that are most abundant within a few cm of the point (example: point intercepted the boundary between *Enchylium tenax*, *Psora decipiens* and a patch of dark cyanobacterial crust, because dark cyanobacteria and *E. tenax* were more abundant within a few cm of the point and *P. decipiens* was not, **either** *E. tenax* or dark cyano biocrust is recorded in the Soil Surf column and the other is recorded in the Soil 2 column, but *P. decipiens* is not recorded as a hit).

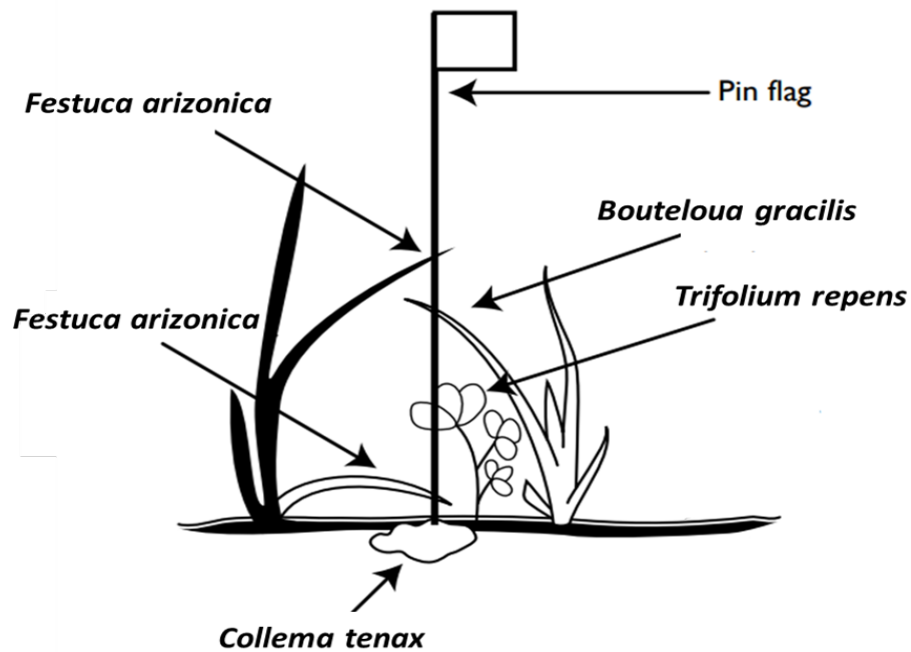

Figure 4. Line point intercept survey modified from Herrick et al. (2017). A pin flag is lowered to the ground surface every 20 cm along the transect (125 interceptions per transect). At this point, the top interception would be identified as *F. arizonica*. *B. gracilis* and *T. repens* would also be listed in that order. A second interception of an already intercepted species at that point (*F. arizonica*, above), does not need to be recorded again. Finally, at the ground surface the lichen *C. tenax* is recorded.

Tier 1. Plant - biocrust co-occurrence survey

This survey will provide a snapshot measuring whether biocrusts tend to be spatially associated with greater or lesser germination and/or establishment of vascular plants. Such spatial (dis)associations provide evidence of, but do not definitively prove, facilitation or inhibition. The methods are designed to target **small** plants at a small spatial scale (e.g. small herbs, subshrubs, or seedlings/ juveniles of any species that are small enough that multiple individuals could plausibly fit within a 25x25 cm quadrat); we operationally define a small plant as one whose canopy coverage is $\leq 25\text{cm}^2$. Larger scale associations between large plants and biocrusts can be gleaned from the **community structure survey**. Although we advise sampling outside of peak annual plant abundance, both annual and perennial plants should be recorded if present.

14. Using the same transects as above, conduct a non-destructive co-occurrence study at five points along each transect (7.5m, 12.5m, 17.5m, 22.5m, 27.5m) for a total of 15 sampling points per site.

- At each point, find two 25x25 cm quadrats, one with the least (closest to bare ground) and one with the most (greatest cover, and if applicable, most

advanced successional) developed biocrusts, occurring within a 2.5 m radius of the point (**Figure 1**). The quadrats may be placed to the left or right of the point, however we caution surveyors to avoid any areas on the left side that were disturbed by previous surveying activity. These quadrats should also not be placed where there is any other clear recent disturbance (e.g. animal burrows). The quadrats should not contain any “large” individual plants, defined here as any plant with a canopy coverage > 25cm². If possible, the quadrat should avoid canopy overlap or shading by any plants larger than the quadrat; however, if impossible to avoid, the pair of quadrats should have similar overlap or shading. If there are multiple possible locations to place your quadrats at a particular transect point, then choose the point closest to the transect line by visualizing concentric circles outward from the transect point.

- Place the quadrat on the ground and document the total visible cover of biocrusts and the predominant type(s) using visual estimates (e.g., 25% light cyanobacterial crusts, 10% lichen crust, etc.). This will help us learn if common types of biocrust differentially affect plant distribution (this purpose does not require any species-level identifications). If any of the biocrust types are present but the cover is less than 1%, use a “T” on the datasheet to indicate “present in trace amounts”. If needed, use the figure in Appendix 11 to guide your cover estimates.
- Obtain a digital photograph (at least 1080p) of each quadrat from 0.35m directly overhead. Include in the image a label denoting the sample identifier such as a legible notebook page or small dry erase board (a.k.a. whiteboard). Strive to clearly capture the small plant individuals present in the quadrat.
- Then, count and record the number of **live** plant individuals rooted in the quadrat present, and the height of the tallest individuals **of each plant species** using the provided datasheet templates. Most plant species can simply be counted as the number of stems emerging from the soil, but in the case of rhizomatous grasses, multiple stems that appear discrete. To count rhizomatous grasses and known clonal species, count as one individual any aggregation of stems separated by <5cm. To correctly measure height, measure the highest part of the plant (rooted or partially rooted in the quadrat) no matter where that part of the plant is (can be outside the quadrat boundaries). Plant height can be measured by moving grass blades or plant stems to their tallest position and measuring from the plant base. Include inflorescences in the measurement. If necessary, collect plant specimens for later identification.
- Note: “Live” plant individuals may be challenging to discern. If senescent plant stems are present at your site, then count them for this survey and include in your description of the species that they were senescent at the time of the survey.

- Note: “Spike Mosses”, such as *Selaginella* sp. can be challenging to count because it is low growing and spreads across the surface. Instead of measuring individual plants, you can use percent cover, as done for the biocrust categories above.
15. Collect node-level soil core composites. After completing both the community structure survey and the plant-biocrust co-occurrence study, obtain two composite samples from within the circular plot.
- Use the three transects established above, sampling soil at the 7.5m, 15m and 25m position along each transect (9 total locations), and pooling it into the appropriate composite. Sample soils on the right-hand side of the tape, which should not have been walked on (above).
 - If any of these sampling locations were inadvertently disturbed by surveyors, or if they contain an anomalous condition such as a large stone or animal burrow or trail, surveyors may move the sampling location to the nearest area unaffected by the anomaly. For example, if a rabbit burrow occupied a sampling location, samplers may move the location to another nearby location representative of the plot in general and sufficiently far from the borrow that it is unaffected by digging or burial (usually an alternative can be found within 50 cm). The presence of vascular plants should not be considered an anomaly in this context. Thus, if a point falls under a plant canopy, samplers should obtain soil there anyway, and if a point is actually occupied by the base of a plant rather than a soil surface, samplers should sample the nearest exposed soil under the canopy.
 - Sample consistently with the general soil sampling instructions above (*All tiers. Soil sampling & handling general overview*).
 - First, use a surface scraping technique, sampling a soil depth of 0-1 cm using hand tools over a surface area of at least 50 cm² at each of the designated sampling locations. Document the area scraped per location; a convenient way to track the area sampled is relative to your sampling tool. For example, a common size for a margin trowel is 5 cm x 12.7 cm. Using a marker, a line can be drawn across the blade 5 cm distant from its end. If the blade is inserted into the soil only up to the line, a 5 x 5 cm area will have been sampled. Two such scrapes, side-by-side would equal 50 cm². If soils are rocky or gravelly, scrape additional area (up to 100 cm²) in each location, but again, please document the area sampled. Record the area sampled on the datasheet.
 - Second, use a coring device (a 50 ml centrifuge tube [aka falcon tube] marked at 4 cm can work) to obtain one or more cores from 1-5 cm in depth from within each scraped area, sampling at least a soil volume of 50 cm³, or up to 100cm³ if soil is rocky or gravelly.

- Pool each subsample into one composite each for the 0-1 cm soil depth, and the 1-5 cm soil depth; each should amount to at least 450 ml of soil and 500 g of soil. It is better to obtain too much soil than not enough.
- Follow the soil sampling & handling general overview to preserve a subsample of both the 0-1 cm composite sample and the 1-5 cm sample for molecular analysis.
- Air dry both composite soil samples if needed and retain the rest of the samples for additional analyses. These samples will be used to measure basic soil properties known to influence biocrust distribution, including texture, electrical conductivity (EC), pH, CaCO₃, and gypsum.
- Overall, this soil composite sampling step of the protocol will generate two soil samples, to be stored dry, and two subsamples of the soils for molecular analysis treated with RNALater.
- Follow instructions in **Appendix 10** to send soil samples to Northern Arizona University.

Tier 1. Biocrust structure - function survey

(This portion of the protocol will require surveyors to distinguish between different taxa and types of biocrusts. Please review the previous section for guidance: *All tiers. Pre-sampling: become familiar with biocrust communities present and develop a classification system for cyanobacterial or algal biocrusts.*)

16. Within your node, select **10** plots (25×25 cm in size) capturing the site’s variability in biocrust properties. These plots will be destructively sampled after a detailed survey is conducted. Plots may be within the 30 m radius plot previously sampled, or elsewhere within the node (**Figure 1**), but cannot have been trampled by surveyors.

- This study requires you to capture the natural variation present in the biocrusts at your site by selecting 10 quadrat locations with differing biocrusts. Variation within a site can be considerable (**Figure 5**). You will employ a gradient design, as opposed to a replicated contrast; thus, each quadrat will be a little bit different, by design. To the degree possible, we’d like you to try to capture 2 gradients: one having to do with the **makeup of** the biocrust community (preferably visible functional diversity) in the quadrats and another having to do with the **amount of** biocrust (cover) in quadrats at your site.
- **“Seeing” functional diversity.** Functional diversity is a calculated property of biocrusts and technically cannot be seen; but there are visible indicators that will help you make a good guess as to which quadrats have the greatest functional diversity. Ignoring biocrust species and types that occur in only trace quantities, a good indicator of functional diversity is the count of the *main kinds* of biocrust visible in a casual observation from a height of 0.5. Example: A sampling location has easily detected patches of light and dark cyanobacterial crusts, three distinct looking kinds of lichen, two distinct looking kinds of moss, and one liverwort. Counting the distinct kinds would yield an estimate of 8. In some cases, surveyors might wish to give extra weight to combinations that include very distinct types. Example: A plot with 3 different lichens with roughly the same growth form would not be as functionally diverse as another plot containing one kind each of cyanobacterial crust, moss and lichen.
- Decide which gradients you think you can capture in your site based on the major ways that biocrusts naturally vary there. Create a grid of locations that you are seeking by dividing a primary gradient (the one that seems to dictate most of the variation) into 5 categories, and a secondary gradient (another key element of the variation) into higher and lower categories. This is best understood with scenarios.

Scenario 1. A site has biocrusts of varying functional diversity, owing to lots of different colorful mosses and lichens present, along with both dark and light cyanobacterial crusts. It also has *some* variance in cover at a small scale, but not extreme, it's just generally high. High functional diversity quadrats have ~8 - 10 major components or types. Low functional diversity quadrats have as few as 1. The surveyors create a grid like this:

	Low Functional diversity (1 - 2 types)	Low-med Functional diversity (3-4 types)	Medium Functional diversity (5-6 types)	Med-high Functional diversity (7-9 types)	High Functional diversity (9 or more types)
Higher than average cover	1 quadrat	1 quadrat	1 quadrat	1 quadrat	1 quadrat
Lower than average cover	1 quadrat	1 quadrat	1 quadrat	1 quadrat	1 quadrat

In it, they selected functional diversity as a primary gradient and cover as the secondary gradient. This creates a list of the kinds of quadrats they are seeking.

Scenario 2. A site has very patchy cover of biocrusts. Individual 25 x 25 cm areas range from having almost no cover to almost 100% cover. Yet, there are only up to 3 or 4 major components or types including dark and light cyanobacteria and only a couple species of moss or lichen. Many potential quadrats have only one major kind of biocrust. In this case it makes sense to invert the grid, using cover as the primary gradient, and functional diversity as a secondary gradient, like so:

	Low cover < 20%	Low-med cover 20 - 40%	Medium cover 41 - 60%	Med-high cover 61 - 80%	High cover >80%
Low Functional diversity 1-2	1 quadrat	1 quadrat	1 quadrat	1 quadrat	1 quadrat
High Functional diversity 3 or more	1 quadrat	1 quadrat	1 quadrat	1 quadrat	1 quadrat

Other scenarios. Every site will be different! There will usually be enough variation in cover to use it as either a primary or secondary gradient. Visible functional diversity is our *preferred* gradient of the biocrust makeup. However, clear visible functional diversity gradients may not exist at a given site (e.g., if all biocrusts are cyanobacterial). In these situations, surveyors may substitute a different gradient related to the makeup of the biocrust, such as inferred successional development, or varying mixtures of taxa and

cover types are two examples. Examples: Based on known successional dynamics in which light cyanobacterial crusts advance successional to become increasingly dark, biocrust darkness could be one gradient while cover is the other. Perhaps in another site with high moss or lichen cover, but not much variation in functional diversity, the moss:lichen ratio could be a useful gradient. In still other cases sites, cover and composition will change in lockstep and cannot be separated. In such instances, surveyors could use a single gradient combining makeup and amount of biocrust into 10 categories.

- Because there are multiple ways to conduct this portion of the study, surveyors may not feel confident that they are selecting quadrats correctly. However, **any sampling that captures the major gradient(s) in biocrust makeup and amount that exist in your site is correct sampling!**
- Using their grids as a checklist, surveyors should locate 25 x 25 cm areas that match the desired combinations of characteristics in the grid marking them with pin flags so they can be surveyed. The match should be based on a rapid visual assessment; it is not crucial to precisely estimate cover, functional diversity (or other properties) during quadrat selection, because these properties will be measured precisely during the subsequent survey. In other words, error in rapid assessments is acceptable.
- Surveyors should avoid strong spatial clustering of the quadrats; maintain a separation distance ≥ 2 m whenever possible. Quadrats should preferentially be placed outside of the canopy of long-lived perennial plants; if this is not possible due to high plant coverage, overlapping of plant canopies is acceptable as long as the quadrat is not placed within 25 cm of the base of a large perennial plant to avoid confusing plant and biocrust effects on function. In addition, surveyors should avoid obvious erosional features and steep slopes not characteristic of the site. It will be impossible to fully know the disturbance history of the microsites, but surveyors should also avoid sampling quadrats compromised by visible disturbances.

Note: Steps 16-19 can be efficiently performed together. Travel to each of the 10 structure-function plots and at each one (i) take photos (ii) record cover using the quadrat (iii) use the chain for surface roughness and (iv) collect samples for aggregate stability, stopping after 5 or 6 to do the aggregate stability test.

17. For each of the 10 quadrats, obtain a high-resolution digital photograph (at least 1080p) of each permanent quadrat from 0.35 m directly overhead. Shadows and sun conditions matter to comparison. Strive for consistent conditions for all photos. Include in the image a label denoting the sample identifier such as a legible notebook page or small dry erase board (a.k.a. whiteboard). Include a scale reference (**Figure 6**), as well as a digital gray card/white balance tool (e.g. [CowboyStudio Micnova Digital Gray Card and White Balance Tools](#)) to one side of the quadrat. Zoom the photo as much as practical while capturing the entire 25x25 cm area and the label, scale bar,

and gray checker/white balance card. Take 2 versions of each photo: underneath an umbrella or parasol to diffuse light and reduce shadows, and in natural light without the umbrella/parasol. Each quadrat will be named with the convention: node lead_three letter node code_plot type (SF)_number (1-10). For example: Bowker_GEI_SF1. The name should be the name of the node lead. Standardized plot reference codes can be found in **Appendix 6**.

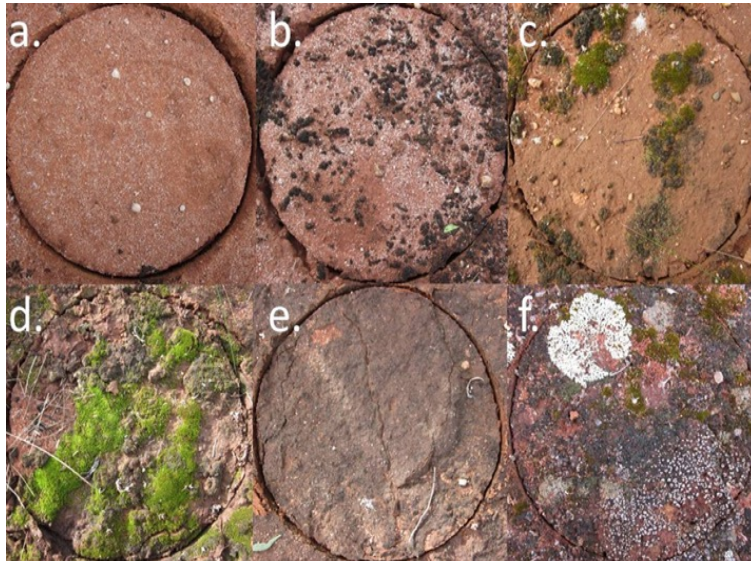

Figure 5. Examples of possible biocrust surfaces observable within one site, illustrating how quadrat selection can isolate major elements of the makeup or amount of biocrust. a. Very low - no biocrust cover. b - c. low-medium cover with low functional diversity, d. High cover with moderate functional diversity, e. high cover with low functional diversity, f. high cover with high functional diversity.

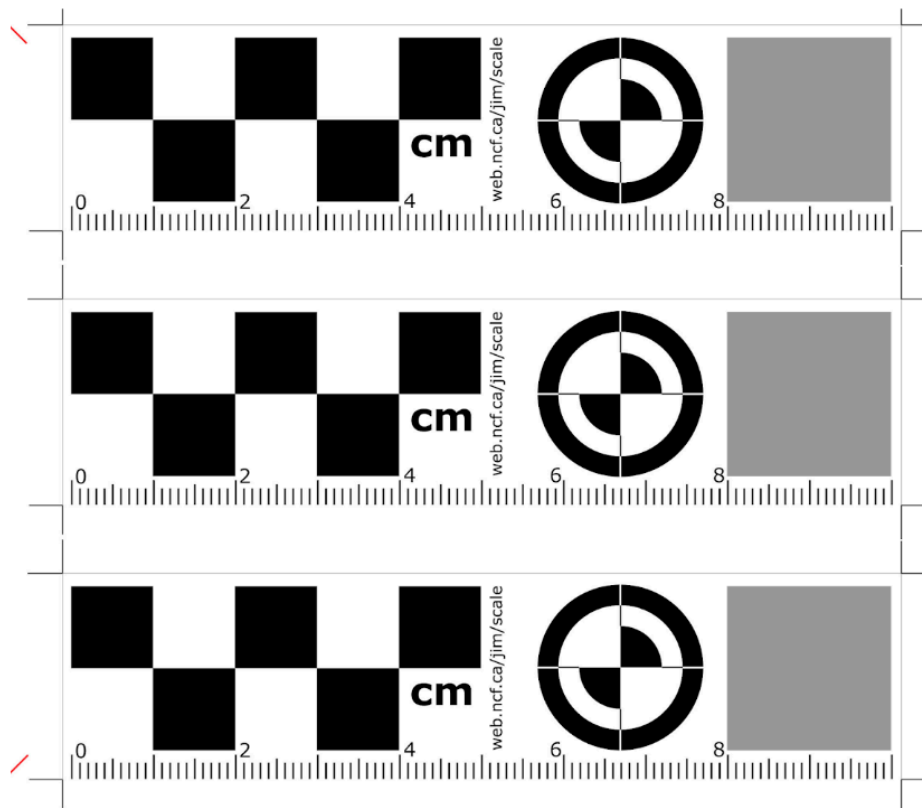

Figure 6. Printable scale reference to be placed in quadrat photos. You will find a laminated version in your sampler’s kit. This scale bar should print to the correct size but check it before going into the field with a ruler.

18. Using a quadrat, assess biocrust cover in each plot. The grid point intercept method of sampling is aimed at capturing cover of different biocrust moss, lichen and liverwort species and, for cyanobacterial or algal biocrusts, the cover type categories assigned in Section 4.2, using the quadrat. The quadrat has an internal dimension of ~25 x 25 cm (**Figure 7**). It may be made of a metal grid or alternatively fitted within a frame of PVC pipe. We have provided in your sampler’s kit a piece of wire fencing material with 25 internal intersection points. We recommend building a PVC frame, and fixing the fencing inside using wire, zip-ties or hose clamps. At each intersection, lower a pin flag vertically to the soil surface and record what is intercepted. Record bryophyte or lichen species identity, and the community type for cyanobacterial or algal crusts (refer to: *Pre-sampling: become familiar with biocrust communities present and develop a classification system for cyanobacterial or algal biocrusts*) in the provided datasheets. Be sure to list any additional species (bryophytes and lichens) or cyanobacterial-algal biocrust types that are present within the quadrat but which were not intercepted. Record intercepts of other ground cover classes as in the **Community Structure Survey**, above.

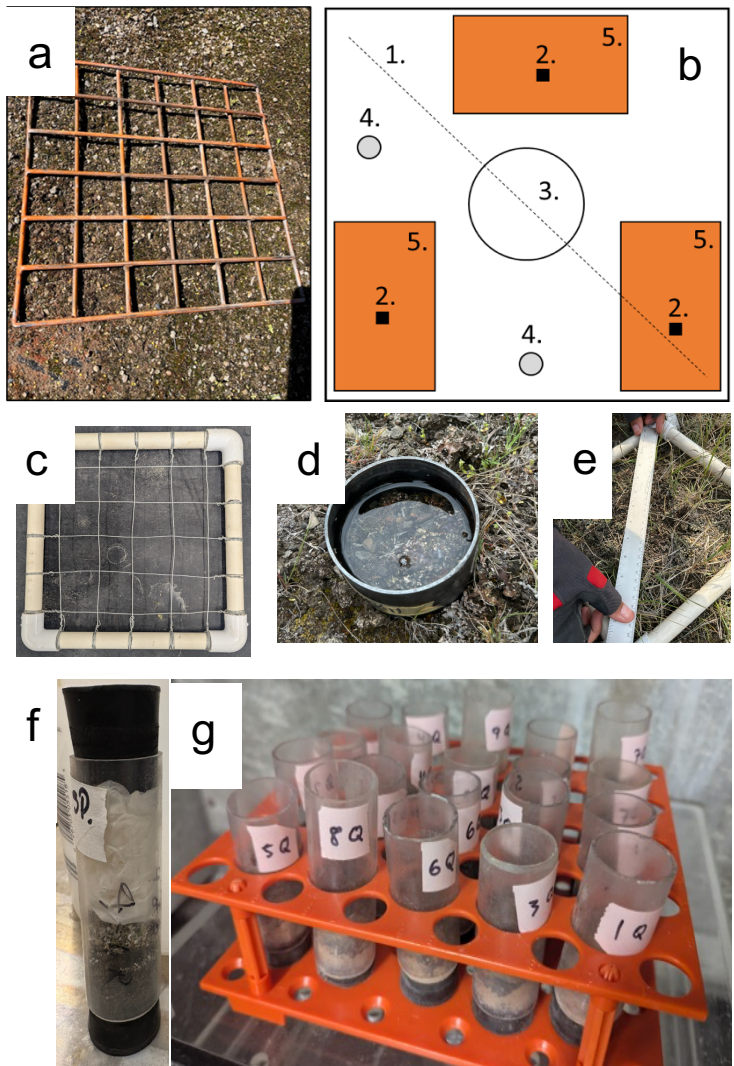

Figure 7. Structure-function survey. **a.** Gridded point-intercept quadrat frame (inner 25 points are used); **b.** Sampling schematic. 1 = placement of jeweler's chain, 2 = soil stability ped sampling locations (random), 3 = infiltration measurement (center; move away from 2 if needed), 4 = N-fixation cores, 5 = collect the soil samples; **c.** Example of another quadrat design; **d.** Infiltration measurement; **e.** Measurement of jeweler's chain; **f.** Filled N-fix tube with ideal ratios of crust, subsoil, and packing material; **g.** Example of N-fix tubes left for air drying.

19. Estimate surface roughness using the chain method (adapted from Saleh 1993). Because biocrust surface topography varies on a very fine scale, a jeweler's chain (also known as a box chain necklace) is used in place of a roller chain. You have been provided with one in your sampler's kit. Lay the chain as straight as possible centered across one of the diagonals of the quadrat being sampled (**Figure 7**). With one end anchored (e.g., with a pin flag), slowly extend the entire length of the chain along a linear path while allowing it to drop into the contours of the soil surface. One could visualize the chain as a straight highway that is going over a series of rolling hills. With the chain draped over the soil surface, measure the linear distance between the two ends of the chain using a ruler. Roughness is calculated as $1 - (\text{straight line distance} / \text{chain length})$.
20. Soil aggregate stability will be characterized using a soil stability kit (Herrick et al. 2017) provided to you. Please review our video for detailed instructions for use of this method with biocrusts <https://crustnet.org/videos.html>, and **practice prior to**

sampling for CrustNet. In each quadrat, sample three **surface** aggregates from standardized locations within the quadrat (**Figure 7**).

- To sample, you will use the metal sampling tool to obtain surface aggregates of the size range indicated inside the box lid, gently trimming it to size if needed. (Avoid touching the aggregate with your fingers or applying pressure). The aggregates should be placed in three of the small sieves in the kit. The kit contains 18 sieves; therefore, it will hold aggregate samples for 6 structure-function quadrats. Arrange so that each column of samples in the box originates from the same plot. Make sure to record the quadrat associated with each on the provided datasheets. If soils are wet, the aggregates must be sampled and air-dried before testing. Remember where these samples are collected so that they do not interfere with the destructive samples in the next section. One option is to collect them along an edge of the plot.
- When an entire box has been sampled (18 aggregates on sieves), you may conduct the measurement. Fill the second box with water and place it next to the box containing your samples. The test consists of a timed immersion of the sieves into the water and uses an ordinal scale to rate aggregates based on their resistance to slaking and to a cycle of dipping (if slaking does not destroy the aggregate). For less experienced users of this technique, we recommend a team of two persons, one to transfer aggregates to the water, conduct the dipping cycle and “rate” stability of the aggregates and the other to act as a timer and data recorder. With experience, a single person can conduct the test. Aggregates are transferred one at a time from a cell of the dry box of samples, to the corresponding cell of the water-filled box, on their sieves. This transfer should occur in the sequence pictured below. A timer should be started at the moment the first aggregate is transferred. Every 15 seconds afterward another aggregate is transferred to the water-filled box following the sequence. Upon this immersion, the person rating stability should determine if any of the aggregates slake and therefore meet the criteria of a 1, 2 or 3 rating (defined on the inside lid of the kit). If slaking did occur, a provisional rating of 1, 2 or 3 should be recorded for that ped using the speed of slaking criteria. If not, the rating should be left blank. When the timer reaches 5:00, the team should return attention back to the first ped immersed and apply a dipping cycle. To implement a dipping cycle and final rating, the sieve should be removed and resubmerged 5 times. During this second observation, an aggregate provisionally rated as 1, 2 or 3 will be verified (if they truly were consistent with a 1, 2 or 3 rating there should be little to no material remaining on the sieve). Aggregates not rated previously will also be given their rating, using the full 6 level scale. These additional ratings are based on the proportion of the original aggregate still present on the sieve after the dipping cycle. As with the initial immersion in water, every 15 seconds the team should proceed to dipping and rating the next aggregate in the sequence. All aggregates in the box are rated in a total of 9m 15s.

Soil Aggregate Stability Kit (positions 1-18)

1 Plot 1 – sample 1	4 Plot 2 – sample 1	7 Plot 3 – sample 1	10 Plot 4 – sample 1	13 Plot 5 – sample 1	16 Plot 6 – sample 1
2 Plot 1 – sample 2	5 Plot 2 – sample 2	8 Plot 3 – sample 2	11 Plot 4 – sample 2	14 Plot 5 – sample 2	17 Plot 6 – sample 2
3 Plot 1 – sample 3	6 Plot 2 – sample 3	9 Plot 3 – sample 3	12 Plot 4 – sample 3	15 Plot 5 – sample 3	18 Plot 6 – sample 3

Note: Steps 20-22 can be efficiently performed together. While the infiltration measurement is occurring, the N fixation and destructive soil samples (scraped, core, molecular) can be collected from around the ring in the plot.

21. Next, an estimate of infiltration under ponding will be performed using a single ring infiltrometer that we provide in your kit. The cylinder diameter that we provide is about 8 cm. You may also use a cylinder you already have or construct your own from a metal cylinder, a tin can (with top and bottom removed) or beveled PVC pipe. It should be at least 10 cm in depth. If you do make your own cylinder, you should test it beforehand to be sure it can be hammered into the soil. If you make your own, you must document the exact inner diameter used. After conducting the cover survey and sampling soil aggregates, insert the cylinder vertically into the soil near the center of the quadrat assuring it does not overlap with any of the aggregate sampling locations or intended soil sampling locations (**Figure 7**). To insert the cylinder, rotate it while applying gentle pressure to cleanly break the surface. We recommend lightly moistening the soil surface where the infiltration test will be done beforehand with a mister spray bottle to minimize cracking of the surface (we recommend a few trials outside of these plots to practice). Lay a short piece of lumber across the top of the cylinder and hammer into the soil using a rubber mallet until about 5 cm of the cylinder is still above the soil surface. The cylinder should be inserted evenly. While still moist, very gently tamp the soil surface inside the cylinder, to close gaps that may exist between the inner wall of the cylinder and the soil within. Line the soil surface inside the ring with a sheet of plastic wrap to completely cover the soil and ring. This procedure prevents disturbance to the soil surface when adding water. Pour a measured amount of water (100 mL) over the plastic wrap lining and prepare to start a timer. Quickly but gently remove the plastic wrap, ensuring that all adherent water goes into the ring. Start the timer at this moment and measure the distance (mm) between the top of the water column and the top of the cylinder in 3 locations. Repeat this measurement every five minutes until the timer reaches 20 minutes. If all of the applied water infiltrates in less than 20 minutes, record the exact amount of time that it took (to the point where there is no standing water, but the soil surface still glistens with moisture) **and** the distances from the top of the can to the soil surface. The

distances will be used, along with the cylinder area to calculate the volume of water that infiltrated at the times recorded.

22. After roughness, soil stability and infiltration measurements are complete, sample two intact cores for N fixation measurement using the provided N fixation tubes (**Fig. 7**). Select locations within the quadrat to sample two 2.5 cm cores using the N fixation tubes in your sampling kit. For each N fixation core sampling location, areas that are representative of the plot. Be sure to avoid the designated soil collection areas and the location of the infiltration test and do not overlap areas where soil aggregate stability samples were collected. Refer to Principle 10 in the Soil Sampling & Handling General Overview for specific instructions and sample drying methods.
23. Finally, sample soil consistently with the general soil sampling instructions above (*All tiers. Soil sampling & handling general overview*). Specifically, you will:
 - First, use the scraping method to obtain one composite sample per quadrat at the depth of 0 -1 cm. The goal is to obtain at least 120 g of dry soil after sieving out rocks and debris; but note that it is better to oversample than under sample. We recommend that you scrape 6 ~25cm² pre-determined areas (e.g. 5 x 10 cm, as shown in **Figure 6**) within the quadrat and pool them in your sample bag for that quadrat; if soils are gravelly, scrape extra surface area but document the total area sampled. When scraping, it is best to avoid areas moistened during either the infiltration test or the sampling of N-fixation cores, to reduce the need for drying soils later.
 - Second, use the provided marked centrifuge tube (or another coring device if needed at your site) to obtain one or more cores from 1cm to 5 cm in depth from within each scraped area, pooling them, sampling at least a soil volume of 100 cm³; if soil is rocky or gravelly, please collect extra cores and add them to your sample; you do not need to document area sampled for subsurface soils of 1 - 5 cm.
 - Follow the soil sampling & handing general overview to preserve a subsample of the 0-1 cm samples and 1-5 cm samples for molecular analysis.
 - Molecular samples can be stored cold (4°C) and then ship at room temperature, following the shipping protocol (**Appendix 10**).
 - Air dry remaining soil of both types of samples (if needed). This portion of the protocol will generate 20 soil samples (10 quadrats x 2 depths) to be used for various biogeochemical and functional assays, and 20 subsamples for molecular analysis. Follow instructions in **Appendix 10** to send soil samples to Northern Arizona University.

Tier 1. Biodiversity survey

The goal of the biodiversity survey is to develop a complete list of macroscopic species (bryophytes, lichens, macrocolonies of cyanobacteria) for the node. Microscopic ASVs will not be ignored but instead will be captured elsewhere (high throughput sequencing of

samples in **Site Characterization**, and in the **Biocrust Structure-Function Survey**, in addition to higher tier components). (This portion of the protocol will require surveyors to distinguish between different taxa and types of biocrusts. Please review section 4.2: *Pre-sampling*). This portion of the protocol will generate no physical samples for subsequent analysis by the receiving lab. However, surveyors may need to return from the field with unknown specimens for later identification in order to complete their species list (Section 4.3: Voucher Specimens).

24. To obtain the species list, we will pool the list of species detected in the **Community Structure Survey** and **Biocrust Structure-Function Survey**, and augment that list with a timed search of the node for additional species. Search effort will be capped at 40 person-minutes, or until no new species have been discovered for 10 minutes. We recommend 2 persons most familiar with mosses, lichens and liverworts search for 20 minutes; searches are meant to span the entire node, not only the areas intensively sampled. Preferred search tactics will intentionally examine areas of high biocrust cover and different microsites (e.g. those in the open and those shaded by plants). The reason this search is timed is to standardize effort per node (each node will have the same number of Tier 1 quadrats and points, and same number of person-minutes searched). Surveyors may choose to spend more time searching for even more species, but any additional finds should be reported separately from this list. We recommend the following workflow:

- Create a provisional list of taxa already detected in other Tier 1 surveying. Surveyors can focus on searching for different taxa, not yet in the list.
- Surveyors walk the site, intentionally investigating varying microsites, employing a “grab and go” strategy. This means they obtain a sample they think could be a newly detected species, but don’t spend time in that moment verifying the identity. Rather they proceed to additional areas and search, obtaining more specimens of possible new species.
- At the end of the search period, collected specimens are reviewed. Duplicates may be grouped together, and species identities completed to the degree possible in the field. A list of new finds is created, and some specimens still requiring further verification are retained for later microscopic observation. Apply advice under *Voucher Specimens* to ensure protection of unknown specimens.

25. Finally, contributors should submit georeferenced photos with metadata of at least the 5 most abundant species at the site using iNaturalist and the “CrustNet” project (<https://www.inaturalist.org/projects/crustnet-global-biocrust-research-network-2be0621d-25c7-405d-87bf-d816ae378d11>). If there are fewer than 5 macroscopic species, strive to submit a photoset for each species. We ask for these submissions even if surveyors are confident in their identifications, because they will help other surveyors identify their species. Suggestions for more useful photos can be found within the iNaturalist project and in the previous section: *All tiers. Pre-sampling*:

become familiar with biocrust communities present and develop a classification system for cyanobacterial of algal biocrusts. Contributors are encouraged to submit photos of additional species when more than 5 species occur, including any collected as unknowns and later identified.

Tier 1. Trait Database

Traits of biocrust species are largely undocumented, yet trait-based ecology is leading to new insights in plant ecology regularly. The same can happen for biocrusts if we create a trait database collectively for major macroscopic species (lichens and bryophytes). We will measure a standard battery of traits for abundant species within each node.

26. Select at least five of the **most abundant** species in each node. To be compatible with this methodology, the species must commonly occur in approximately monospecific patches of at least 1 cm² (the 5 most abundant species will usually meet this criterion but if one does not, attempt to sample the next most abundant that does meet the criterion). If fewer than 5 species occur, attempt to sample the whole flora. If greater than 5 species occur, please consider sampling additional species, emphasizing either widely distributed species, to help understand trait plasticity, or species that are unique to your region, to add new information to the trait database. **For each species, collect at least 15 typical specimens** using knives, small trowels or other hand tools. Here, “typical” means that specimen diameters are within the normal size range for the site, with practical constraints. For species that occupy large patches, sample a portion of the patch about the size of a standard petri dish (~9cm diameter); otherwise sample the entire coverage of the specimen.

- If collection is easy, or if specimens tend to be small, we ask that contributors collect up to **10 extra specimens**. If this level of sampling might deplete the species in the node, samplers may also search ecologically similar adjacent areas outside of the node.
- Strive to collect enough underlying soil that the entire “root zone” (rhizoids and rhizines) is captured, usually 2 cm depth is sufficient but that may vary by species and site.
- Initial wetting may be helpful for sampling and transport, if transport distance is short.
- We suggest wrapping and padding with tissue and placing them in food storage containers for transport back to the lab. Additional advice for protecting more fragile specimens can be found under *Voucher Specimens*, above. Do not keep wet specimens in plastic containers for more than a few hours. If they were wet when collected, or if you wetted them, air dry the samples at room temperature for storage until they can be sent to the receiving lab.
- To prepare for sending to the receiving lab, please review the instructions in **Appendix 10**. It is key that they arrive intact!
- This portion of the protocol will generate a variable number of physical moss, lichen or liverwort specimens (75 as described above, potentially < 75 if species richness is low, potentially > 75 more if extra specimens or species are attainable). Send samples to Northern Arizona University using the provided

instructions in **Appendix 10**, where they will be used to measure biocrust traits. We will model our trait methods after Mallen-Cooper & Eldridge (2016), and subsequent modifications by Mallen-Cooper et al. (2018).

This concludes Tier 1 of CrustNet. Congratulations!

At the end of Tier 1, you should have:

- 1 surface composite sample in a plastic bag
- 1 subsurface composite sample in a plastic bag
- 20 N-fix cores (2 per Structure-Function (S-F) survey plot) in N-fix tubes
- 10 scraped surface 0-1 samples (one 120 g sample per S-F survey plot) in a plastic bag
- 10 subsurface 1-5 cm samples (one 120 g sample per S-F survey plot) in a plastic bag
- 2 subsamples (from two composite samples) in 5 mL tubes, covered with RNALater
- 10 subsamples (from 10 Structure-Function samples at 0-1 cm) in 5 mL tubes, covered with RNALater
- 10 subsamples (from 10 Structure-Function samples at 1-5 cm) in 5 mL tubes, covered with RNALater
- ~75 trait specimens in Tupperware & tissue

5.3 Tier 2

Tier 2 consists of optional observational studies (which require fewer samples), and two simple low-cost experiments that must be repeatedly sampled. Experimental Tier 2 activities require maintenance of a node for at least 3 years and must be sampled at least 3 times. Tier 2 nodes may need to accommodate a greater number of permanent quadrats (depending on which elements are performed), thus must not be space limited. At this time, our funding allows us to process samples from up to 25 Tier 2 nodes for most elements; 10 nodes with good geographical spread will be considered adequate for most elements. Please signal your interest in conducting Tier 2 on the intake form, during a virtual meeting with the Leadership Team, or by email (sierra.jech@nau.edu & matthew.bowker@nau.edu) prior to sampling, so we can provide guidance. Tier 2 will document resistance and resilience to disturbance (**Disturbance-Recovery** and **Disturbance Gradient Experiments**) and will encompass some targeted collections and sample provision (**N-cycling & Spectral Reflectance of Biocrust Types**).

Tier 2. Experiments. Preparing the site & establishing plots.

In total, if all possible elements are undertaken, Tier 2 will require the creation of 32 additional plots (**Figure 8**), encompassing two different experiments and each containing a permanent monitoring quadrat in the center. The two experiments are the **Disturbance-Recovery Experiment** and the **Disturbance Gradient Experiment**.

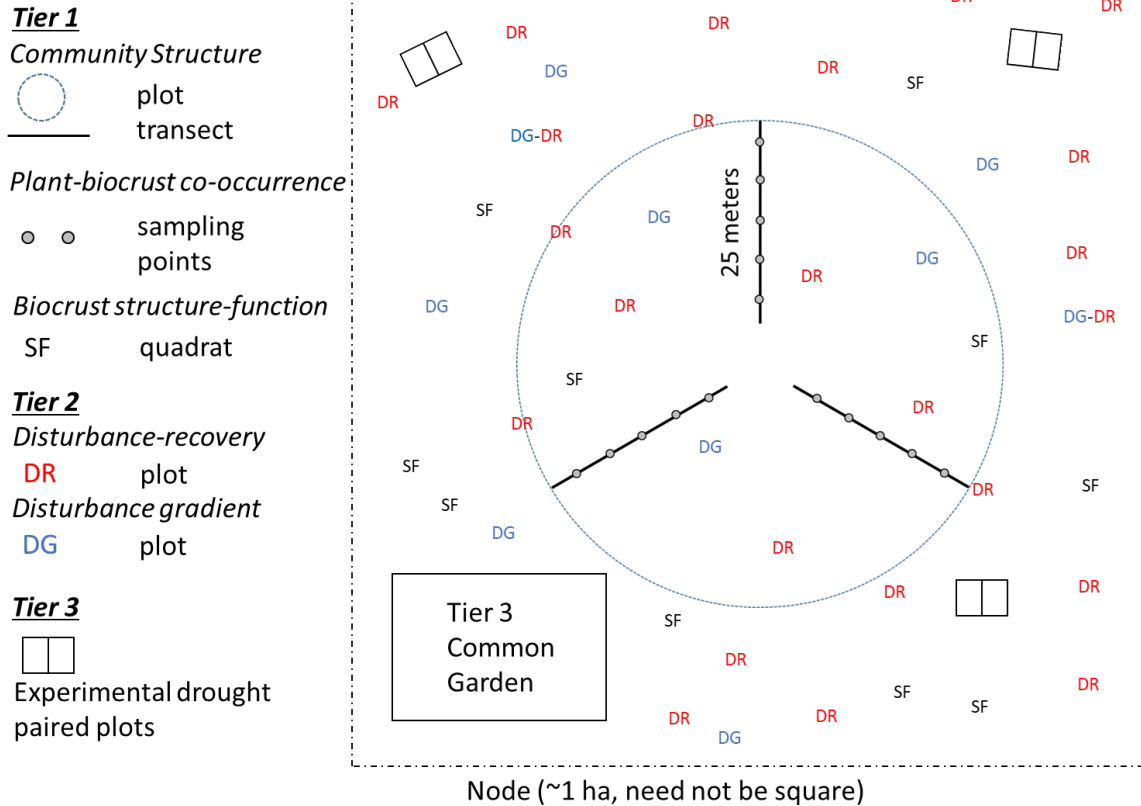

Figure 8. Overall schematic of an example node with components of **all** tiers, highlighting permanent Tier 2 experimental plots. Some components/activities are not shown because they are distributed collections across the whole node (Biodiversity Survey, Trait Database, N-cycling and Spectral reflectance of biocrust types), rather than being isolated to quadrats, plots or transects. All pictured quadrats (SF or PB) are 25 x 25 cm. Tier 1 includes a total of 40 quadrats, each sampled once. All pictured Tier 2 plots (32) are sampled a total of three times. Tier 3 components are described in the Tier 3 section, below. Note that distribution of plots will vary at each node based on the criteria needed for each experiment.

27. The first step in preparing your site is to decide whether you are conducting just one or both of these studies, and if you will perform optional add-ons. Doing more of the studies will enable you to participate in more of the papers. To determine how many plots you will need, calculate like so:

- If you will do the **Disturbance-Recovery Experiment** (excluding optional add-on), **add 16 plots**.

- *If you will do the optional add-on of the **Disturbance-Recovery Experiment**, **add 8 plots**. (note: you may only do the **Disturbance-Recovery** optional add-on if you also do the main **Disturbance-Recovery Experiment**)*
- *If you will do the **Disturbance Gradient Experiment** and were already planning to do the **Disturbance-Recovery Experiment** (above), **add 8 plots**.*
- *If you will do the **Disturbance Gradient Experiment**, but do not plan to do the **Disturbance-Recovery Experiment**, **add 10 plots**.*

Possible numbers of plots needed depending on the decisions above are 0 (if you choose not to participate in Tier 2 experiments), 10, 16, 24 or 32. We will send you a randomization scheme for your plots - unique to each sampler - both in your sampler's kit, and by email.

28. **Mark plots.** Across the node, select the required number of plots, mark the corners, establish observer position, and familiarize yourself with the plot sampling design.

- First, mark approximate diagonal corners with temporary markers such as a pin flag or bamboo pole.
- **Plot composition.** Plots should feature well-developed examples of the dominant or typical kind of biocrust assemblage present at your node. Example: In a site where most biocrusts are cyanobacterially dominant, with patches of lichens dispersed throughout, these plots should reflect that typical condition. If there are multiple dominant or typical kinds, select one kind to focus on. Example: In a site where large moss-dominant biocrust patches and cyanobacterially dominant biocrust (with scattered lichens) are both prevalent, choose one or the other to focus on. Each plot must have an area of at least 0.5 × 0.5 m and should be at least 1m distant from the nearest neighboring plot.
- **Route.** To minimize disturbance, it is recommended to have a consistent route or path that can be followed through the node, traveling efficiently from plot to plot. Mark the route if needed.
- **Quadrats for demarcation.** We recommend using PVC quadrats of two different sizes to help visualize and mark your plots: 0.5 × 0.5 m and 0.25 × 0.25 m. First, place the 0.5 × 0.5m quadrat around the selected plot, then place the 0.25 × 0.25m quadrat in its center.
- **Permanent center quadrat.** Using the smaller quadrat as a guide, mark the corners of the 0.25 m × 0.25 m permanent quadrat to be monitored, using tried-and-true methods for your study site. Options that various samplers have used include documenting GPS coordinates and accuracy of the center of each quadrat, along with installing long nails or landscape staples to mark monitoring quadrat corners. Then, mark at least 2 diagonal corners of the larger plot (the area outside of the monitoring quadrat, but within the larger

quadrat will be a destructive sampling quadrat) using wooden stakes, steel bars or other materials that you know will work in your site.

- **Visibility.** We recommend painting and flagging tops of markers if the location is reasonably secure to enhance visibility; but do not recommend this practice if vandalism is a concern. If animal disturbance (e.g. trampling, burrowing) is a major concern, we recommend marking diagonal corners of each plot with steel bars driven at least 30 cm into soil.
- **Redundant markers.** Affix redundant plot identity markers at each plot; for example, you may write the plot number directly on a stake, in addition to writing plot numbers (and treatment information, if applicable) onto flagging or tags wired to plot markers or painting them onto nearby stones. Again, use the techniques that you are confident will work in your site to ensure re-finding of the plot. We also recommend making a site map recording location, identity and treatment information about the plots.
- **Observer location.** At each plot, designate a standard location where the observer will stand to conduct monitoring (for example, north of the northernmost edge of the plot) so that damage to the area surrounding the quadrat is constrained. **Figure 8** summarizes the layout of the plots. Though there are some differences between the activities in the **Disturbance Gradient Experiment** and the **Disturbance-Recovery Experiment**, the main zones of the plot are the same and monitoring crews must familiarize themselves with them to ensure proper sampling.
- **Learn main plot zones.** When the observer occupies their standardized location, 4 main zones of the plot can be envisioned (**Figure 9**). In the plot center is the permanent monitoring quadrat. It should never be disturbed for the duration of the study. To the left of the monitoring quadrat is a portion of the plot that can be used for destructive sampling in observation 1 (encompassing initial pre- and post-treatment monitoring). On the opposite side of the monitoring quadrat from the observer is a portion of the plot that can be used for destructive sampling in the second semi-annual observation. Finally, to the right of the monitoring quadrat is a similar area that can be used in the third semi-annual observation. It is crucial to use this clockwise rotation of destructive sampling to avoid allowing destructive sampling activities conducted in an early time point to affect results of those in a later one. In case a sampling area is exhausted and additional sampling areas are needed, areas near the plot corners are reserved for that purpose.

Note: Specific instructions for establishing the two disturbance experiments differ, thus they are treated separately in the following sections.

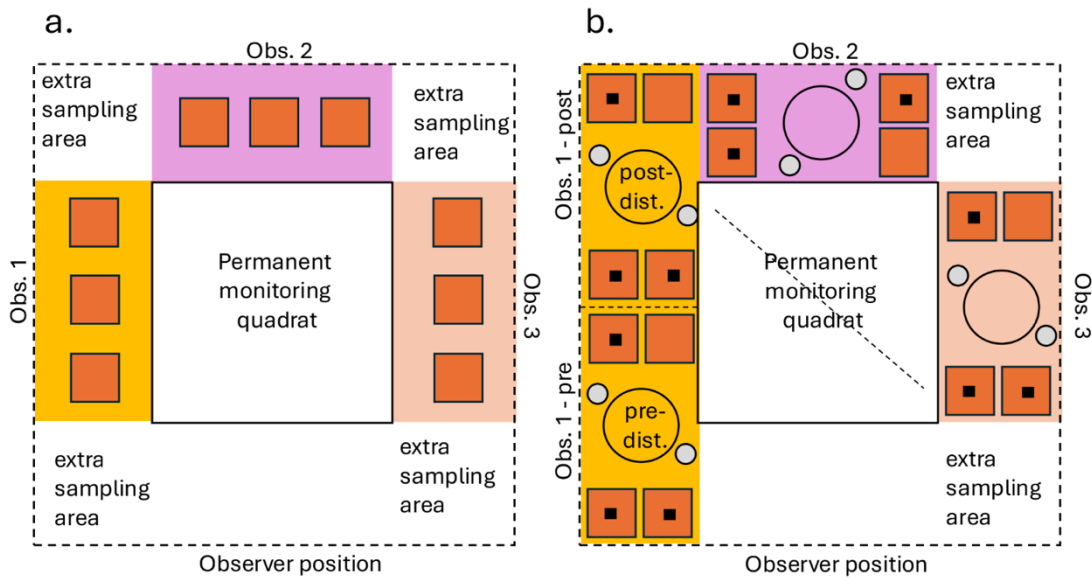

Figure 9. Monitoring schematic of repeated sampling in tier 2 with each sampling area (box) having a length and width of 0.5 meters. **a.** The **Disturbance-Recovery Experiment** will focus on capturing structural changes including cover and photomonitoring in the central permanent quadrat. Colored fields represent areas in which destructive measures can be performed, rotating with each observation. Orange boxes within the colored fields represent destructive soil sampling patches (~ 5 x 5 cm each) for monitoring of microbial indicators in pooled soil samples, **b.** The **Disturbance Gradient Experiment** will also use photomonitoring, and cover measurement, but will focus on functional measurements very similarly to the **Biocrust Structure-Function Survey**. Solid box represents permanent monitoring quadrat used only for non-destructive sampling and roughness measurement (dashed line). The sampling area for Observation 1 is split into a pre-disturbance (lower left), and a post-disturbance (upper left) sampling area. Large unfilled circles indicate placement of single ring infiltrometers. Gray circles represent locations for N-fixation cores. Small black square represent soil aggregate sampling locations. Orange boxes again represent destructive soil sampling patches (~ 5 x 5 cm each), to be sampled only after soil aggregates are obtained.

Tier 2. Experiments. Disturbance-Recovery Experiment.

This experiment will use 16 of the marked plots with randomly assigned treatment designations (or 24 if the optional inoculation add-on is performed). Mark the plots using techniques described above (**Tier 2. Experiments & Repeated Monitoring. Preparing the site & establishing plots**).

29. Disturbance-recovery experiment. After plot establishment, travel to each plot and implement disturbance if the plot is designated as disturbed, then perform the monitoring activities. Do not disturb the plots designated as undisturbed; they must remain undisturbed for the duration of the experiment. If the plot is undisturbed, go right to the monitoring activities. If you are doing the inoculation add-on, wait to do these plots until the initial 16 disturbed and undisturbed plots are complete so that inoculation amount can be calculated.

- **29.1 Disturbance.** In all plots designated to receive disturbance you will apply a disturbance over the entire surface of the plot. Disturb plots by striking the entire surface with a small sledgehammer meant to be swung with one hand (head mass: 3 - 3.3 lb (1.36 - 1.5 kg); face diameter: 35 - 45 mm; swing velocity: fall from ~0.5 m height with gravity; **Figure 10**). This disturbance will simulate the pressure exerted by hoof action of heavy livestock. Disturbing the whole surface will require about 120 – 150 strikes (no need to count) which should be administered systematically *until the entire surface has been disrupted in this way*; we recommend a controlled short swing, holding the elbow close to the soil surface (~ 10 cm), elevating the hammer nearly vertically, and allowing it to fall with the force of gravity, while guiding the fall to a desired location. Please see our video here <https://crustnet.org/videos.html>, avoid striking the same surface repeatedly.

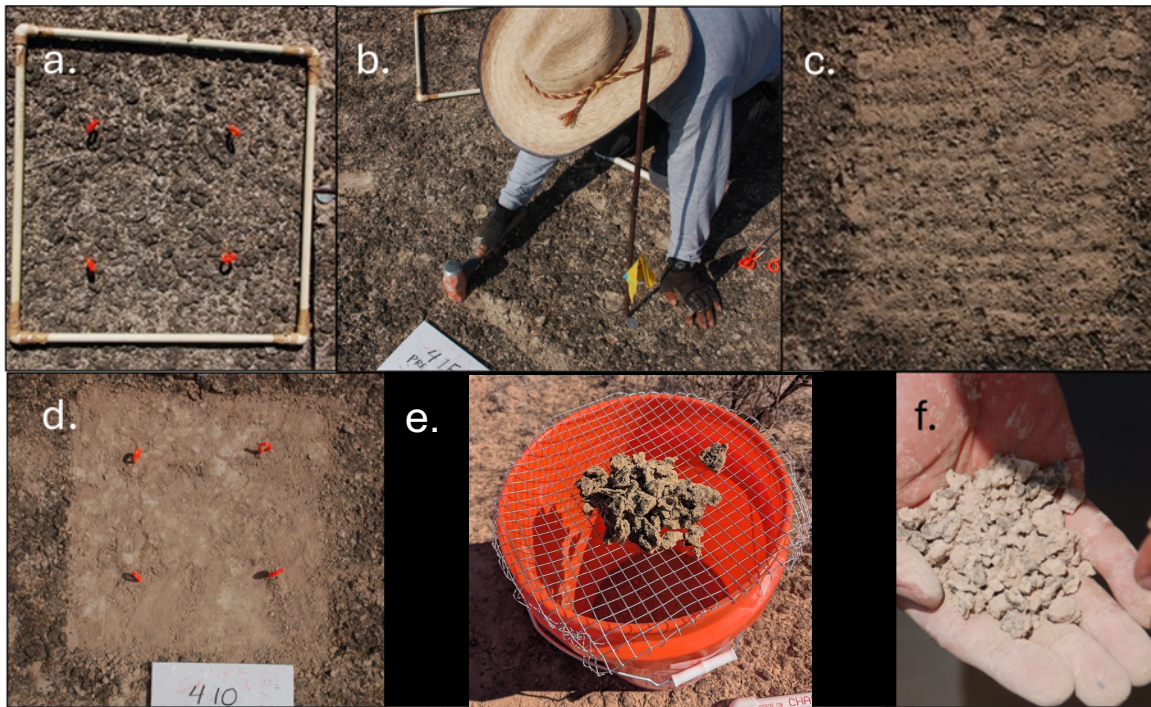

Figure 10. Key steps in the establishment of the **Disturbance-Recovery Experiment**. **a.** An example plot prior to disturbance; orange aluminum stakes mark the permanent monitoring quadrat. **b.** Systematic disturbance of plot using a sledgehammer. **c.** A plot after complete disturbance was applied with the sledgehammer. **d.** Scraping to harvest inoculum. **e.** Preparing biocrust inoculum. High cover/quality biocrust material scraped from surfaces is passed through a 1 x 1 cm screen to disaggregate it and remove stones. You can use a sieve if you have one, but hardware cloth over a bucket works well. **f.** The resulting inoculum (to be added to inoculation treatments).

- **29.2 Monitoring.** After the disturbance you will implement monitoring.
 - **29.2a: Photo.** Take a high-resolution photo (~0.7 m height) of each monitoring quadrat with a ruler and label and the entire plot in the frame, before and after disturbance as applicable (undisturbed plots require only one photo per time point).
 - **29.2b: Cover quadrats.** Collect biocrust cover data using the methods described for the **Biocrust Structure-Function Study**. We are recording only soil surface categories (not plants) in this study.
 - **29.2c: Scrape sample.** In the designated destructive sampling zone (for observation 1 it will be the area to the observer's left of the permanent monitoring quadrat), sample soil consistently with the general soil sampling instructions above (*All tiers. Soil sampling & handling general overview*). As depicted in **Figure 9**, scrape three discrete 5 × 5 cm areas to a depth of 0 - 1 cm, pooling the soil into one sample for that plot. (note that no 1 - 5 cm soil samples are taken in Tier 2).

- **29.2d: RNA subsample.** Preserve a subsample of each soil sample using RNALater as described in (*All tiers. Soil sampling & handling general overview*).
- **29.3 Inoculation. *Optional add-on*:** If you have chosen to conduct the optional add-on to this study and have consulted with the PI Group about your plans, you will have created 8 extra plots. Before disturbing these plots using the technique described below, first inoculate them.
 - **29.3a: Obtain inoculum.** To do so, first obtain some inoculum (**Figure 10 d-f**). **Outside of the plots**, harvest the equivalent of 2 plots (~ 0.5 m²) worth of high biocrust cover by scraping it. The scraped material need not be contiguous. Scraping consists of complete removal of soil surface to 1 cm depth using flat trowels or other hand tools (**Figure 2**). Metal dust pans are ideal tools when rock cover is low, smaller brick trowels may be used for rocky soils (**Figure 2**). Retain the scraped biomass in buckets. Before inoculating, remove rock fragments > 1 cm, and disaggregate material by passing through a 1 cm mesh sieve (**Figure 10**); note that hardware cloth bent over the top of a bucket can function very well as a sieve.
 - **29.3b: Calculate addition rate.** Calculate mean total cover of biocrusts based on your cover data from the undisturbed plots. To do that, divide the number of intersection points in the grid-point intercept quadrat in which you intercepted biocrust types by the total number of intersections (25), for each plot, then average those results. Calculate 25% of that value. For example, if the undisturbed average cover is 40%, then your goal would be to add back the equivalent of 10% cover (40% x 25% = 10%). Then, convert that coverage value to volume assuming 1 cm depth. Continuing from the previous example, a plot is 2500 cm², 10% of that area is 250 cm², therefore the volume of biocrust to be added (assuming a depth of 1cm) would be 250mL. The calculated volume will differ from site to site as a function of the undisturbed biocrust cover at that site.
 - **29.3c: Apply inoculum.** To apply inoculum, measure the desired volume and sprinkle it from a cup or other container, dispersing material across the entire plot. If possible, avoid doing this on a windy day. Apply inoculum without adding
- **29.4 Revisitation.** Return to the plots semi-annually (two times over 3 years). Maintain and replace any plot markers. Do not re-disturb or re-inoculate the plots. Instead, follow the steps to monitor the plots (Section 29.2).

Tier 2. Experiments & Repeat Monitoring. Disturbance Gradient Experiment.

This section will use the remaining 8-10 0.5 × 0.5 m² marked plots that contain typical biocrust cover and development for the site; the number depends on whether you are also performing the **Disturbance-Recovery Experiment** (consult the provided randomization sheet). Briefly, you will be using a sledgehammer similarly to the **Disturbance-Recovery Experiment** but disturbing differing proportions of the plot area (100%, 75%, 50%, 25%, and 0% disturbance; 2 of each level). Unlike the **Disturbance-Recovery Experiment**, you will monitor both composition/development of biocrusts, and their function, both before and after implementing the disturbance.

Generally, sampling will begin in the central monitoring quadrat with cover, roughness, and plot photos. Then, outside of the permanent monitoring quadrat, in the designated sampling areas (**Figure 9b**), functional assays will proceed from less destructive to more destructive. Since this sampling has destructive components, the location to be sampled will move clockwise annually as seen in **Figure 9b**. The designated sampling area in observation 1 is larger than for observations 2 & 3, because it must accommodate both pre- and post-disturbance sampling. In general, samplers will apply the same functional measurements as the **Biocrust Structure-Function Survey**, except that the locations of some types of sampling and the recommended sequence of the measurements will be altered because the size and shape of the sampling area is different. **Figure 9b** illustrates the locations of the measurements you will make and samples you will take. As an aid to implementing this sampling mentally divide the sampling area 1 into quarters along the lengthwise axis. The first infiltration test will straddle the 3rd and 4th quadrants of the plot, centered along the short axis.

30. **Disturbance-gradient experiment.** Perform pre-disturbance monitoring, disturbance, and then post-disturbance monitoring

- **30.1 Pre-disturbance monitoring**

- **30.1a: Photo.** Take a high-resolution photo of each monitoring quadrat.
- **30.1b: Cover quadrats.** Collect biocrust cover data using the methods described for the **Biocrust Structure-Function Study** in the permanent monitoring quadrat.
- **30.1c: Roughness.** Estimate surface roughening across the diagonal of the permanent quadrat using the jeweler's chain method (see **Biocrust Structure-Function Study**).
- **30.1d: Infiltration.** Moving outside of the central monitoring quadrat, in the designated location for infiltration (**Figure 8b**), measure infiltration using the single-ring infiltrometer as described above in the **Biocrust Structure-Function Study**. Note: it may be advantageous to start this measurement first at each plot if infiltration is slow at the site as it can take up to 20 minutes per plot.

- **30.1e: N-fixation.** Collect the two intact cores for N-fixation measurement on either side of the placement of the infiltration ring, as shown in **Figure 9b**. The goal is to collect a sample with no more than 1cm of soil below the biocrust. Refer to Principle 10 in Soil Sampling & Handling General Overview for instructions on drying these samples.
- **30.1f: Aggregate stability.** Collect at least 3 peds for the soil aggregate stability test, near the center of three of the marked soil sampling zones in the 3rd and 4th quadrants of the sampling area. Note that if these are wet when sampled, they must be air-dried prior to measurement.
- **30.1g: Scrape sample.** Sample soil consistently with the general soil sampling instructions above (*All tiers. Soil sampling & handling general overview*). Scrape and pool the entire surface of the four 5 x 5 cm soil (**Figure 9**) sampling zones using a flat-bladed hand tool to a depth of 1 cm, into a sampling bag. The goal is to obtain ~120 g of mineral soil once rocks and debris are removed. If soils are likely to contain substantial rocks and debris, collect extra soil by adding more 5 x 5 sampling zones, but be careful not to disturb the permanent quadrat or take samples within 5 cm of it. Also, document the total area sampled if different from 100 cm².
- **30.1h: RNA subsample.** Preserve a subsample of surface soil using RNALater as described in (*All tiers. Soil sampling & handling general overview*).

Notes: If soils must be taken wet due to a rain event or because of spillage from the infiltration test, allow to air-dry in a cool location while in the field. Never seal wet samples in plastic bags. The locations of any of these measurements, especially the infiltration test (which is only performed in one location) may be shifted if the suggested location is atypical of the disturbance level, or if it contains some other kind of anomaly. If shifts are necessary, we advise adjusting locations of the other measurements to minimize alterations to the overall configuration of measurements and sampling.

- **30.2 Disturbance.** After pre-disturbance data and sampling has been completed, apply the prescribed rate of disturbance using the sledgehammer (**Figures 10 & 11**), and maintain it annually to simulate a chronic disturbance.
 - **30.2a: Complete disturbance plots.** To disturb the plots designated for 100% disturbance, systematically hammer the surface in rows until the whole 50 × 50 cm plot has been struck (as in the **Disturbance-Recovery Experiment; Figures 10 & 11**). Avoid overlapping strikes to the degree possible. Disturbing the whole surface will require 120 – 130 strikes.

- **30.2b: Strike number for partial disturbance plots.** To disturb 25%, 50%, and 75% of the plots is more difficult. First, estimate the number of strikes per plot that will be needed. If you follow our guidelines in selecting a sledgehammer, the head will be about 4 cm wide. When striking a soil surface, this will leave a disturbed area about 5 cm in width or diameter. Confirm the size of the disturbance generated by your hammer, by making some test strikes off plot. Measure the length and width of the disturbed area in the case of a square hammer head, or the diameter in the case of a round hammer head. Calculate the area of the disturbed area (for example a round disturbance with a 5 cm diameter covers an area of 19.7 cm²). Since the total plot area is 2500 cm², the target areas of disturbance in our disturbance gradient are 625 cm² (25% disturbance), 1250 cm² (50% disturbance), 1875 cm² (75% disturbance). To arrive at the needed number of strikes per disturbance level, divide the target disturbance areas by the single strike disturbance area, rounding to the nearest value. For example, using a hammer that generates a 19.7 cm² disturbance would lead us to calculate $625/19.7 = 32$ (25%), $1250/19.7 = 63$ (50%), $1875/19.7 = 95$ (75%).
- **30.2c: Strike pattern for partial disturbance plots.** Our goal is to strike the designated proportion of the plot in a near-random but also spatially balanced pattern (**Figure 10**). The goal is **not** to hammer the same pattern every year, rather, each year a different pattern will be disturbed. Over time, these overlapping near-random disturbances will result in mosaics of different frequencies of disturbance, similar to a chronically grazing-disturbed site. We recommend by beginning with a single strike haphazardly placed anywhere in the plot, then aim your next strike in the most empty part of the plot. Repeatedly apply each successive strike in the most empty part of the plot, keeping a count of how many strikes, you have made. When you are approaching your last few strikes in a plot (~ 3 – 4), assess whether you've generated a reasonably spatially balanced pattern. One aspect of spatial balance to take note of is the number of strikes that fell within the permanent monitoring quadrat. Since the permanent monitoring quadrat is about one quarter of the plot, then about one quarter (~22.5% - 27.5%) of the strikes should be within it, and about three quarters outside. Adjust the placement of the few remaining strikes to help correct any major deviations from spatial balance.

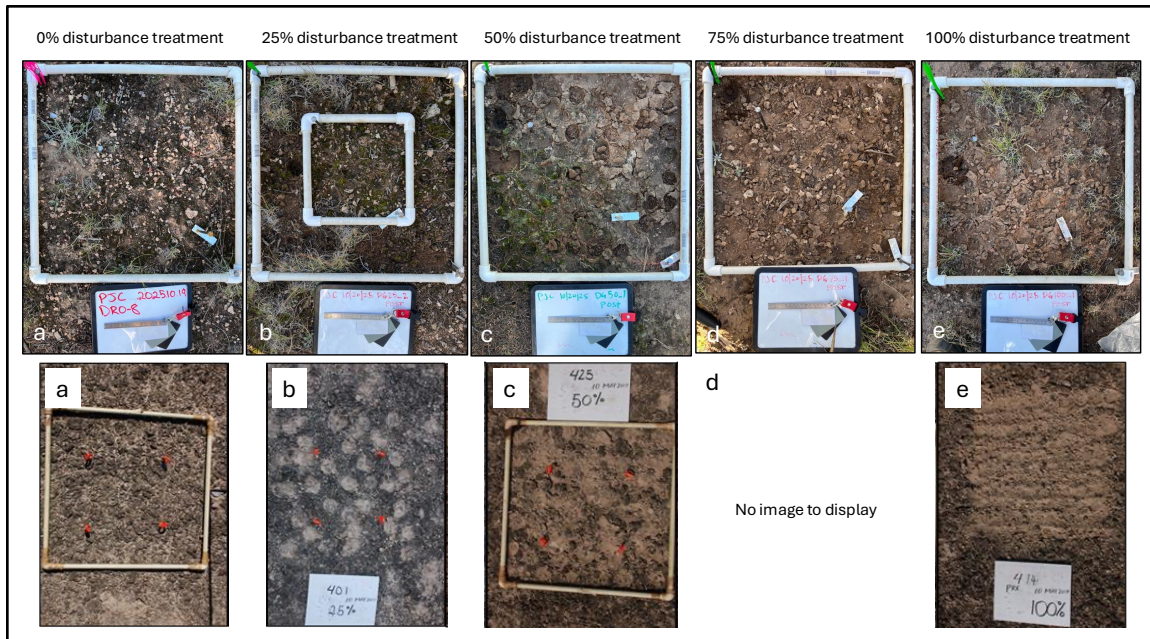

Figure 11. Establishment of the Disturbance Gradient Experiment using different densities of sledgehammer strikes, applied in a haphazard but spatially balanced pattern. Top row shows a set of plots from a node with small vascular plants present and the bottom row shows a set of plots from a different node where the hammer strikes are more clearly visible. **a.** 0% disturbance. **b.** 25% disturbance. **c.** 50% disturbance. **d.** 75% disturbance. **e.** 100% disturbance.

- 30.3 Post-disturbance monitoring.** After the initial disturbance, please repeat collection of the cover data, photographs and surface roughness measurement in the permanent monitoring quadrat. Then repeat the remaining functional measurements (infiltration, N-fixation core samples, soil aggregate stability, soil collections) but shift the location of these measurements and samples to center on the 1st and 2nd quadrant of the designated sampling area. *Note that this only occurs in the disturbed plots; the undisturbed controls do not need post-disturbance monitoring.*
- 30.4 Re-visitation.** These plots will be revisited semi-annually (2 additional times within a 3-year period), for monitoring and re-treatment. In these revisits, first obtain photos using the same methods as in Observation 1 and measure cover in the permanent monitoring quadrats. Next, re-apply the designated amount of disturbance with the sledgehammer as described above. Then, conduct all functional measurements as described above and illustrated in **Figure 9**. As described in **Figure 9**, the designated sampling zone for destructive sampling will rotate clockwise around the permanent monitoring quadrat in the second (opposite side of permanent quadrat from observer) and third visits (to the observer's right from the permanent quadrat). Finally, take photos of the plot after disturbance to document the treatment.

At the end of the first sample time of tier 2, if you do all components you should have:

	DR0	DR100	DRI	DG pre	DG post	Totals
Bags of soil	8	8	8	8	8	40
Tubes of soil	8	8	8	8	8	40
N-fix tubes	4	0	0	16	16	36

- 40 scraped surface 0-1 samples (one 120 g sample per plot, including both pre- and post-disturbance in the disturbance-gradient experiment) in plastic bags
- 40 RNALater subsamples in 5 mL tubes
- 36 N-fix cores in N-fix tubes. There should be 4 per disturbance-gradient plot because of pre and post sampling, but only 2 for the two control plots)

5.4 Tier 3

Tier 3. Overview.

Tier 3 consists of optional experiments requiring investment of funds and infrastructure, travel and possible coordination among different groups of node samplers. The subject matter of Tier 3 is the response of biocrusts to climate change pressures using different types of simulated climate change. Our target is to conduct a rainfall reduction study in 15 locations worldwide. Another target is to conduct 2+ node transplant studies in at least 3 nations (instructions are still being developed at this time).

Tier 3. Experimental drought manipulations.

Partners will select additional permanent quadrats to be placed underneath rainfall reduction shelters and monitor biocrust response. Drought structures were modeled from DroughtNet (<https://droughtnet.weebly.com/>) and the USGS Southwest Biological Science Center experiments with biocrust-sized drought structures. Shelter designs can be found in **Appendix 8. CrustNet Rainfall Reduction Shelter Design and Installation.**

31. **Plot selection.** Select a total of three pairs of plots similar in most respects to **Tier 2. Experiments. Preparing the site & establishing plots**, except that they must have physical space around them to install a rainfall reduction shelter with a basal footprint of 1 m². The two plots within each pair should be as close to each other as possible, and no more than 5 m distant. Position the plots so that the shelter does not shade the control plot, or if shade is not a concern, randomly designate (e.g., coin flip) one plot per pair to become a rainfall reduction plot, and the other as a control plot. Position the plots so that:
 - i. First, the rain pouring off the drought structure will not flow onto its own plot or the nearby control plot. To do this, consider landscape slope and pre-existing water flow patterns on the ground.
 - ii. Second, the shelter does not shade the control plot. To do this, consider the position of the sun throughout the year and where the shade will most consistently travel. Choose the control plot to be outside this shaded zone.
 - iii. Third, the prevailing direction of wind and storms at your site so that the structure will intercept rain.
 - iv. Fourth, if the above factors are not a concern at your site, then randomly designate (e.g., coin flip) one plot per pair to become a rainfall reduction plot, and the other a control plot.
32. **Mark the plots.** Use permanent plot markers appropriate for your site, similarly to **Tier 2. Experiments. Preparing the site & establishing plots**.
33. **Install soil moisture monitoring instruments.** If you have access to continuous soil moisture probes and data loggers, install them under both the shelters and the paired control plots. Common models include Campbell CS655, Meter ECH2O EC-5 or 10HS,

or TEROS 11. If possible, install probes horizontally or diagonally and aim to capture the surface moisture ~0-5 cm depth. An alternative is to collect gravimetric soil moisture in the extra sampling zones during visit 2 and visit 3 so that we can calculate the percent difference in soil moisture under the shelters and control plots. Protocol here: ([Gravimetric Soil Moisture Protocol](#))

34. **Construct and place the shelters.** Assemble according to **Appendix 9. Rainfall Reduction Shelter Installation Instructions.**

35. **Install the shelters.** Detailed instructions are given in **Appendix 9** Install three 1 x 1 x 1 m³ rainfall reduction shelters (**Figure 12**) at the designated rainfall reduction plots. Shelters can be secured to the ground with two different designs. If your soils will allow rebar down ~0.5 meters, then you can use Design A. If your soils are shallow or rocky, rebar will not go into the soil, then you will need to use Design B. Please consult the Leadership Team for advice, if needed.

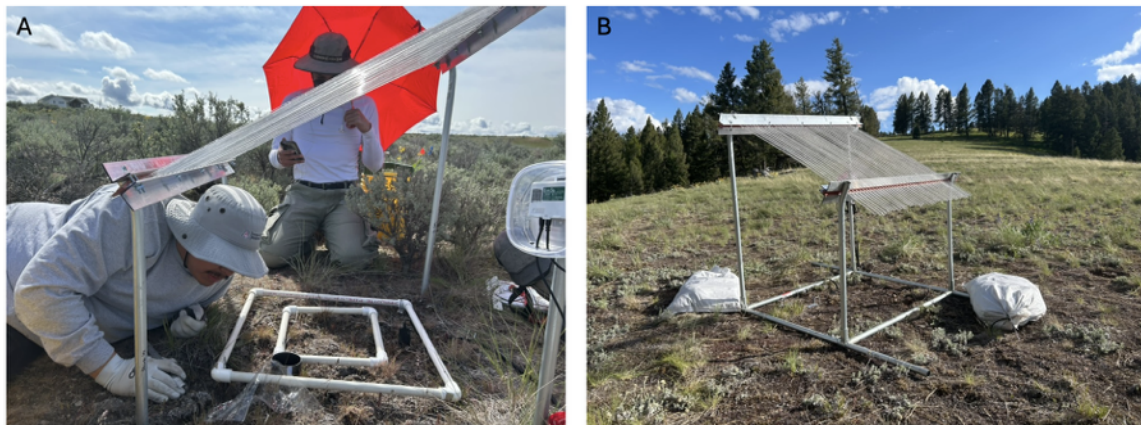

Figure 12. A) Example rainfall reduction shelter with a researcher using a 0.25 x 0.25 m² quadrat frame for biocrust monitoring in the non-destructive section of the monitoring plot. B) Sandbags hold the rainfall reduction shelter in place where we could not use rebar in the ground.

36. **Monitor.** Follow the instructions for monitoring in the **Tier 2 Disturbance Recovery Experiment**. Monitor once per visit and rotate around the plot for the destructive sampling procedures as shown in **Figure 13**. The **Drought Experiment** will also use photomonitoring, cover measurement via grid-point intercept, and several functional measurements. Each sampling location on the schematic is reserved for the three years of the experiment. **We will not collect N-fix samples for this experiment. Please do collect molecular sub-samples** from the homogenized 0-1 cm soil sample bags, following the methods described in Soil Sampling & Handling General Overview.

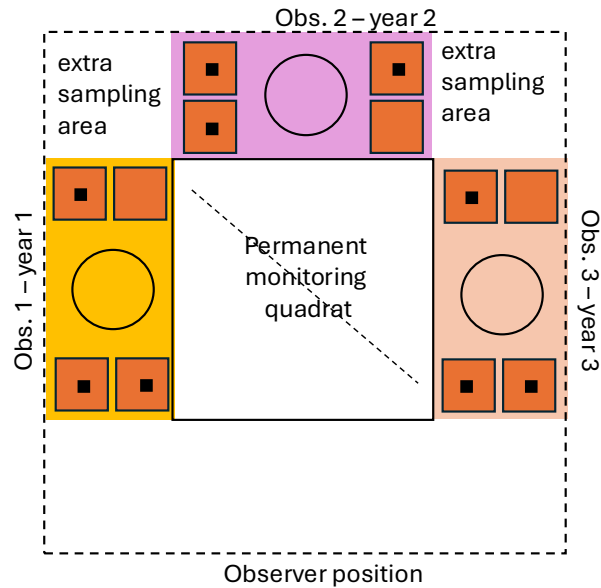

Figure 13. Monitoring schematic of repeated sampling in Tier 3 with each sampling area (dashed outer box) having a length and width of 0.5 meters. The **Rainfall Reduction Experiment** will use photomonitoring and cover measurement but will focus on functional measurements very similarly to the **Biocrust Structure-Function Survey**. The solid box represents the permanent monitoring quadrat used only for non-destructive sampling and roughness measurement (dashed line). Large unfilled circles indicate placement of single ring infiltrometers. Small black squares represent soil aggregate sampling locations. Orange boxes again represent destructive soil sampling patches (~ 5 x 5 cm each), to be sampled only after soil aggregates are obtained.

At the end of the first sample time of tier 3:

- 6 scraped surface 0-1 cm samples in plastic bags
- 6 RNALater subsamples in 5 mL tubes

Tier 3. Common garden study.

[Detailed instructions are coming in 2026!](#) Briefly, partners will collect intact samples of biocrusts and transplant them intact to other nodes varying in abiotic conditions and monitor the response. This is a major method to simulate climate change, for example moving a biocrust sample from a cooler site to a warmer one. Since long distance transport across national borders is likely illegal (and unethical), transplants should be coordinated between multiple research groups *in the same nation* and in observance of applicable laws. The Leadership Team can assist with planning such experiments and connecting teams. Initially we would compile a list of interested participants to connect different research groups within a nation. Each node sampler would commit to providing 10 transplants to each intranational cooperator in addition to replanting 10 transplants in the source node.

First, the CrustNet Leadership Team will determine in which nations such a study might be plausible and reach out to CrustNet participants from that nation. The CrustNet Steering Committee and interested Tier 3 participants will co-develop the final design and protocols.

6.0 Data Submission

We encourage data and photo submission via cloud-based links rather than email. We recommend that you organize all of your files in one folder and use the 'share link' function within your cloud storage environment of choice (e.g., Google Drive) to send us a link to your data. Alternately, if you prefer, we can send you an upload link or a link to shared folder where you can upload your files.

We will ask for photos of your datasheets that you used in the field and a digital version of your data that you enter into an Excel or Google Sheets with different sheets for the different experimental components. We will also check that you submitted all of the transect and plot photos.

We will leave it up to you to post your biocrust species to iNaturalist (<https://www.inaturalist.org/projects/crustnet-global-biocrust-research-network-2be0621d-25c7-405d-87bf-d816ae378d11>). Please reach out to us if you need assistance.

References

Herrick JE, van Zee JW, McCord SE, Courtwright, EM, Karl, JW, Burkett, LM. 2017. Monitoring manual for grassland, shrubland, and savanna ecosystems. Vol 1:Core Methods. USDA ARS Jornada Experimental Range, Las Cruces, NM.

Mallen-Cooper M, Eldridge DJ 2016. Laboratory-based techniques for assessing the functional traits of biocrusts. *Plant and Soil* 406: 131-143.

Saleh A. 1993. Soil surface roughness measurement: chain method. *Journal of Soil & Water Conservation* 48:527-529.

Additional Resources

Appendix 1. How the Leadership Team Can Support Your Node Installation

Appendix 2. Suggested Field Sampling Flow

Appendix 3. Field Checklist

Appendix 4. Material Checklist & Tier 1 Diagrams

Appendix 5. Tier 2 Checklist

Appendix 6. Suggested Plot Naming & Labels

Appendix 7. Additional Optional Experiments

Appendix 8. Rainfall Reduction Shelter Design

Appendix 9. Rainfall Reduction Shelter Installation Instructions

Appendix 10. Instructions for Shipping Imported CrustNet Samples

Appendix 11. Ocular Cover Estimate Guide

Appendix 1. How the Leadership Team Can Support Your Node Installation

Please contact us at any point to discuss challenges, opportunities, and questions about node installation. We are happy to provide guidance and support! Here are a variety of ways that the CrustNet leadership team plans to support CrustNet node installations.

1. **Taxonomic assistance** - we urge samplers to be/become experts in their biocrust species. We also encourage nodes to post photos of their unknown specimens to the CrustNet iNaturalist project so that the whole community can help ID.
2. **Permitting** - each node is responsible for obtaining the correct permission for conducting scientific experiments and land disturbance.
3. **Sampling kits** - will be sent to you upon request. Please let us know which items you need. We will work with you to decide a timeline for returning these items.

The table below shows the sampling kit items that we can provide. Prior to sampling, please send us a list of which items you need via email or via the online form (available at <https://crustnet.org/>)

Items we can provide upon request	An example of what we use
N-fixation tubes and stoppers	These were purchased from United States Plastic Corp. and then cut to size and bevelled. Contact us for more information if you are going to make them from scratch
jewelry chain for measuring surface roughness	Example from Amazon.com
soil aggregate stability kits	Example from Forestry Suppliers
margin trowel	Example from Home Depot
infiltrometer ring	you can use PVC or metal to make a 4" diameter ring that is 3" tall
50 mL Falcon tube for coring the soil	Example from Biotechnology Solutions
labeled 5 mL tubes for soil samples going to molecular analysis (RNase free, DNase-free, polypropylene)	Example from Fisher Scientific
RNA Later (we make this in-house so please do not buy your own)	

disposable pipettor for transferring RNALater to the 5 mL tubes	we just pour the solution and do not need a pipettor. If you need one, you could use something like this: Example from Amazon.com . Please ensure that it is sterile and DNase/RNase-free
printed ruler from the protocol	we use a small metric ruler for our photographs like this: Example from Amazon.com
plastic bags for soil collection	We use Whirlpak bags or Ziploc bags that have a white label area for marking the bag with Sharpie. Whirlpaks can be found here: Example from Whirl-Pak
Grey balance cards for digital color correction	Example from Amazon.com
60 mm petri dishes with tape or parafilm to keep them closed during transport	Example from Fisher Scientific
AirTag for shipping samples	Example from Apple
Paper sample labels (used to redundantly label plastic bags of soil if your sharpie labels rub off)	You can make your own by handwriting labels on paper
Printed datasheets	
Gloves (nitrile or latex for subsampling soil samples into tubes for molecular work)	

The following items are necessary for completing this work and will not be provided in a sampling kit. Please reach out if you need assistance obtaining or making these items, as we can help coordinate between nodes.

Tier 1

GPS (with batteries)
Clinometer
Compass
Camera (phone camera is ok)
Biocrust ID guides
Pin flags
Knee pads and other safety gear
Clipboards
Pencils, pens, sharpies, dry erase markers
Transect tape
0.25 x 0.25 m frame (PVC works great)
Rubber mallet
Small ruler (10 cm)
Medium ruler (1 foot)
Umbrella
White board
Paper towels, toilet paper, paper bags, tissue paper for wrapping samples
0.25 x 0.25 m frame with 25-point grid – one option is to build a PVC frame and then cut wire fencing to the right size. Attach the wire fencing to the PVC frame with zip ties.
Spray bottles
Wood block
Water (both tap and distilled)
Jar or bottle to measure 100 mL of water while in the field
Plastic wrap
Timer (phone timer is ok)
Plastic bags (Ziplock, Whirl-Pak, or other)
Metal spoon or spatula
70% ethanol in a bottle

Tier 2 – many of the materials in the Tier 1 list plus:

Permanent plot markers (for example aluminum tags on landscaping staples or 6" nails)
0.5 x 0.5 m frame (PVC works great)
3 lb. sledgehammer
Bucket or tub to collect inoculum
1 x 1 cm grid or screen to homogenize inoculum
Measuring cup to inoculate the right amount on each plot

Tier 3

All of the structure components listed in **Appendix 8**

Soil moisture probes with data logger and batteries or other energy source

Sample shipping

Printed permit (525-22-318-20470R1_A-00741759_11-12-2025)

Printed PPQ Form 550

Box for shipping

Packing materials to cushion the samples

Triple containment for the samples

Piece of paper with the shipping address and contact information

A packing list of what is in the box and approximate mass or volume

Appendix 2. Suggested Field Sampling Flow

This assumes you will do all CrustNet components and that you have a team of 5-7 people for about 5-6 days.

Prior to arrival

- Create a random numbers sheet with values 1-32
- Look at online resources to make a list of the possible plant and biocrust species you will encounter. Create 6 letter codes for each, comprised of the first three letters of the genus name and the first three letters of the species name. For example, for *Syntrichia ruralis*, the code is SYNUR.
- Label your plot markers, bags, and tubes

Day 1 on site

- Look at your plant and biocrust species to ensure that you know their identities and assign unknown codes to the unknowns. Take voucher specimens and take photographs of the unknowns for future reference.
- Determine the center point for the LPI transects. Use pin flags to mark the LPI transects and warn the crew not to walk within 3 m of the transects.
- Establish a walking path as needed.
- Carefully look around the site and identify 32 potential Tier 2 plots. Use pin flags to mark them so that no one will disturb them.
- Carefully look around the site to identify all 10 Tier 1 plots. Use pin flags to mark them and take photos to compare side-by-side. It may be helpful to create a digital document to compare plots - double check that a gradient exists. Make sure that you feel good about your cover gradient and your richness decisions based on the protocol rules.
- Take photos of the biocrust species, plant species, and landscape. In the evening make your team a concise list of species, names, and codes that can be referred to often in the field. I used the Notes App on my phone and then took screenshots to share with team members

Day 2-5 on site

- Team 1 (2 people). LPI transects. Assign plant-biocrust cooccurrence plots along the transects and mark with pin flags prior to measuring LPI to avoid disturbance. LPI will take ½ to 2 full days.
- Team 2 (2 people). Cover team. Visit all plots in the following order and read the cover:

- a. Disturbance-Recovery control plots – you need these values to calculate the inoculum that you will add to Disturbance-Recovery inoculation plots
 - b. Disturbance-gradient plots – you need to get these started early because they will be monitored twice
 - c. Structure-function plots – get these done so that another crew can do the functional measurements and destructive sampling
 - d. Save the Disturbance-Recovery (100%) and Disturbance-Recovery Inoculated plots for last because then you won't slow down Team 3 too much
- Team 3 (2-3 people). Function team. Visit all plots AFTER the cover team has gone through. Do photos, surface roughness, aggregate stability, water infiltration, and destructive sampling. Wait to monitor the Disturbance-Recovery (100%) and Disturbance-Recovery Inoculated plots until they have been disturbed or disturbed+inoculated. Do not forget to monitor Disturbance-Gradient plots before and after disturbance! Be sure to record “pre” and “post” on all bags, tubes, and datasheets associated with Disturbance-Gradient plots.

Other tasks for team members to complete as time allows:

- Trait collections
- Plant-biocrust co-occurrence plots along the LPI transects (likely best for Team 1)
- Biodiversity survey + collect vouchers
- Spectral petri dishes (optional experiment from Appendix 7).
- Install & monitor Tier 3 rainfall reduction shelters (this can be done by 1 person, but 2 is better)

Tips:

- Separate samples for molecular analysis at a tabletop that has been cleaned with 70% ethanol. Homogenizing the bags and then taking subsamples is a lot easier in a comfortable place where you can sit and relax. Clean your workstation and tools with 70% ethanol. Clean your hands and use gloves. Clean your gloves with 70% ethanol.
- It is a good idea to have consistency in who measures cover and who measures function across the site or at least have everyone trained together. Training can happen on Day 1 or 2 but will significantly extend the amount of time required for the work. Sierra was able to train 5-6 people in half a day for the entire protocol.



Appendix 3. Field Checklist

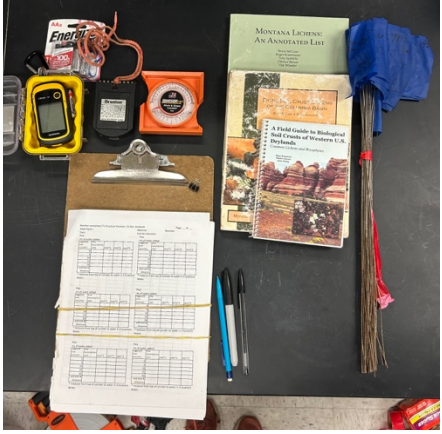
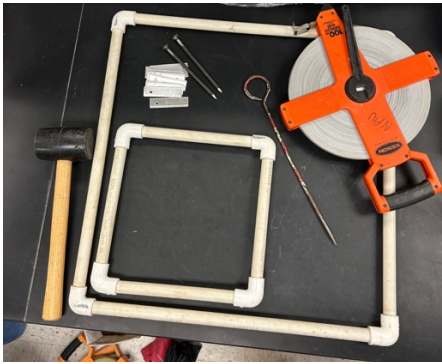
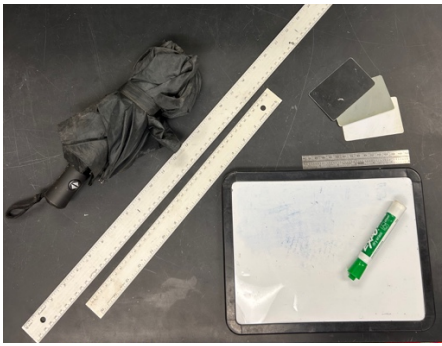
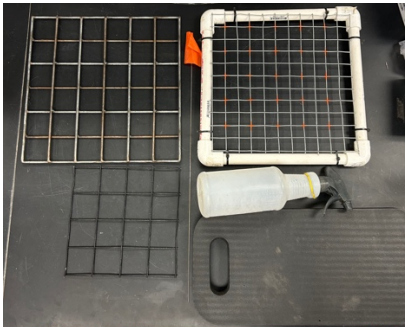

Node characteristics	
	Establish a walking path & central gathering area close to vehicles and away from the main node area
	Photos of your biocrust development system
	Site Metadata datasheet GPS of the node center point slope, aspect, landscape characteristics, soil types, parent material visually appealing photos of the landscape and organisms vegetation cover, species, exotics 1 composite soil sample (0-1 cm) from 3 positions (x3 transects) 1 molecular sub-sample 1 composite soil sample (1-5 cm) from 3 positions (x3 transects) 1 molecular sub-sample
Tier 1	
	LPI datasheets photo of each transect
	Plant-biocrust cooccurrence datasheets 10 quadrats (x3 transects), photo of each quadrat
	10 Structure-function plots & datasheets photos (sun & shade) w/ ruler, balance cards, plot labels measure cover, roughness, aggregate stability, N-fix cores, infiltration 10 soil samples (0-1 cm), record area sampled 10 molecular sub-samples 10 soil samples (1-5 cm) 10 molecular sub-samples 20 N-fix cores, labelled
	Biodiversity survey biocrust species list (w/ codes) plant species list (w/codes) voucher specimens, labelled photos for iNaturalist (5+ species)
	Biocrust traits specimens 15 specimens (x5 species), labelled and carefully packed for shipping

Tier 2	
	<p>Disturbance plots label up to 32 plots with permanent tags (ensure redundancy in tags) 8 undisturbed (DR0) 8 disturbed 100% (DR100) 8 disturbed 100% & inoculated (DRI) 8 disturbed at different levels (DG100, DG75, DG50, DG25) GPS points for all plots & hand drawn site map monitoring & disturbance datasheets photos cover, roughness, N-fix, aggregate stability, infiltration 40 soil samples (0-1 cm) – 8 DR0, 8 DR100, 8 DRI, 8 DG pre, 8 DG post 40 molecular samples 36 N-fix tubes (10 DG pre (n=2 per plot) and 8 DG post (n=2 per plot))</p>
Tier 3	
	<p>install 3 shelters & 3 control plots permanent plot markers (ensure redundancy in tags) monitoring datasheets photos cover, roughness, aggregate stability, infiltration 6 soil samples (0-1 cm) 6 molecular samples install soil moisture probes (optional), check batteries</p>
Appendix 7 (Optional)	
	<p>Spectral reflectance samples 8 replicates of up to 6 biocrust types in petri dishes</p>
Clean up	
	install whisker plot markers, if using
	remove all pin flags or other temporary plot markers
	double check all nuts and bolts on rainfall reduction shelters
	photos of site & landscape
	pick up all field gear and trash

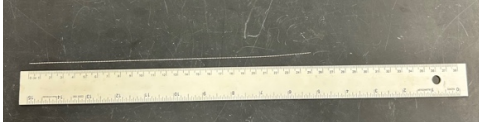
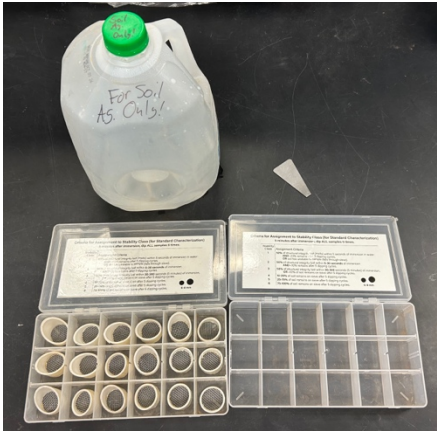
Appendix 4. Materials Checklist and Tier 1 Diagrams

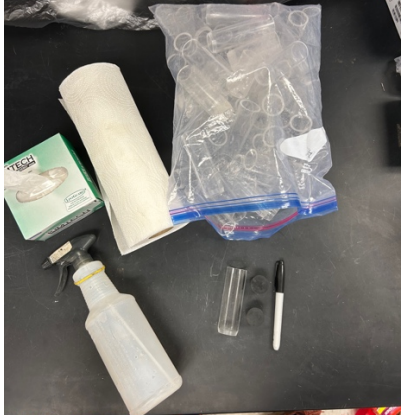
<p>Node establishment</p>	<p>GPS clinometer compass biocrust ID and plant ID guides pin flags knee pads printed datasheets printed protocol clipboard pencils, pens, sharpies</p>	
<p>Plot & transect Establishment</p>	<p>transect tape (>30 m) with metal stake aluminum tags (labelled, 2 per plot) staples (4 per plot) large quadrat small quadrat mallet GPS (w/ batteries)</p>	
<p>Photos</p>	<p>ruler (0.35 m height or 0.7 m height) umbrella phone white board dry erase marker photo balance cards small ruler paper towels</p>	
<p>Cover</p>	<p>25-point frame spray bottle pin flag knee pads biocrust ID guides</p>	

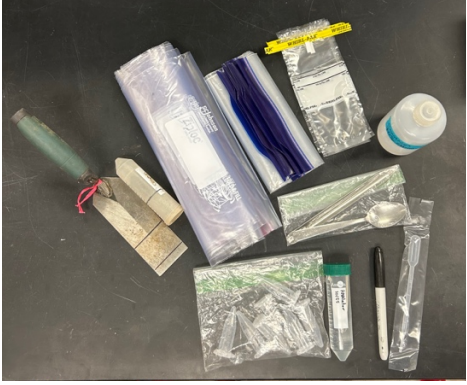
<p>Roughness</p>	<p>chain with known length medium sized ruler (cm markings)</p>	
<p>Aggregate stability</p>	<p>soil Ag box with small soil ped sampling tool record the box ID and position in box</p>	
<p>Infiltration</p>	<p>metal ring wood block mallet water water bottle with 100 mL marked Saran wrap timer small ruler (cm markings) spray bottle (if soil is dry)</p>	
<p>N-fix</p>	<p>spray bottle (if soil is dry) paper towels or toilet paper sharpie stoppers N-fix tubes quart sized Ziploc bags</p>	

<p>Soil samples</p>	<p>margin trowel (marked at 1 cm and 5 cm) 50 mL Falcon tube marked at 5 cm Ziploc bags sharpie molecular tubes, labelled spoon or other metal tool to transfer soil into tubes ethanol or isopropanol</p>	
<p>Biocrust vouchers and trait samples</p>	<p>plastic tackle box for viewing species (optional) paper bags toilet paper or paper towels to wrap specimens hard sided Tupperware for protecting samples</p>	

Tier 1 Diagram for Reference – print a copy for your clipboard in the field

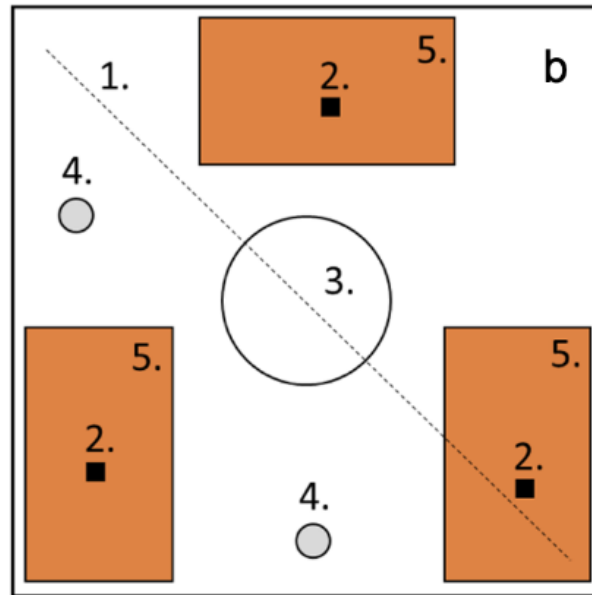

Figure 7B. Sampling schematic. 1 = placement of jeweler’s chain, 2 = soil stability ped sampling locations (random), 3 = infiltration measurement (center; move away from 2 if needed), 4 = N-fixation cores, 5 = collect the soil samples. Note: N-fix cores locations should be representative of the plot, follow the protocol instructions.

Cover codes Table for reference in the field

Ground surface categories	Description	Example code for datasheets
Leaf litter	detached stems, roots, leaves, and leaves	LEAF
Woody debris	detached woody or succulent litter that is greater than 5 mm in diameter	WOOD
Duff	partially decomposed plant matter	DUFF
Dung/scat	Animal dung or scat	SCAT
Animal matter	Decomposing animal material (e.g., carcass, bone, etc.)	ANMAT
Inorganic litter	Plastic, metal	INORG
Vagrant lichen	do not record as crust, do identify species	VAGRLIC
Rock lichen	do not record as biocrust, species identification not needed	ROCKLIC
Gravel	5 - 76 mm	GRAV
Cobble	>76 – 250 mm	COBB
Stone	250 – 600 mm	STONE
Boulder	>600 mm	BOULD
Bedrock	Exposed bedrock of any size	BEDR
Eolian Sand	Recently deposited	SAND
Animal digging	Burrows, forage pits	ANDIG
Animal trampling	Hoof print	ANTRP

Appendix 5. Tier 2 Checklist (print this double sided and use in the field)

Materials: In addition to the list in **Appendix 4** you will need a sledgehammer, a tool to scrape and collect biocrust (bucket), 1 x 1 cm gridded screen for homogenizing biocrust inoculum

Use this table to keep track of which plots you have visited and any notes about methods that still need to be done.

	1	2	3	4	5	6	7	8
DR0								
DR100								
DRI								
pre-disturbance	DG100	DG100	DG75	DG75	DG50	DG50	DG25	DG25
post-disturbance	DG100	DG100	DG75	DG75	DG50	DG50	DG25	DG25

DR0 plots

- Monitoring type A
- Monitoring type B for two random plots _____ & _____

DR100 plots

- Photo
- Smash 100%
- Monitoring type A

DRI plots

- Photo
- Smash 100%
- Inoculate
- Monitoring Type A

DG plots

- Photo
- Monitoring type B (pre disturbance), make sure cover is read
- Smash (to 25%, 50%, 75%, or 100%)
- Monitoring type B (post disturbance)

Monitoring Type A

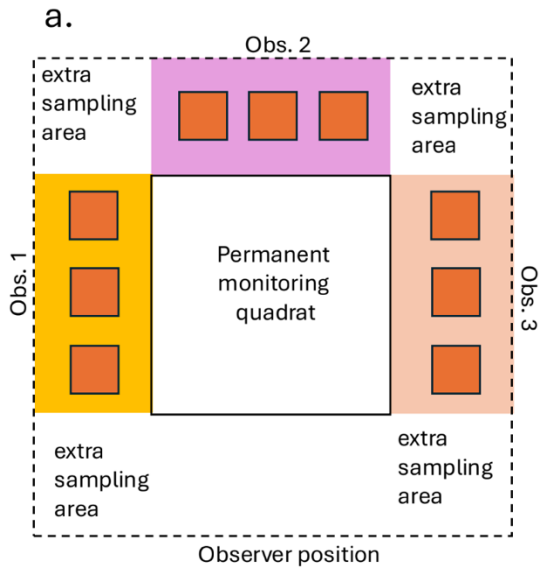

- Take a photo of the plot (75 cm high)
- Measure cover in the permanent monitoring quadrat at the center
- Take three soil samples (each 1 cm deep and 5x5 cm area), pool into a single bag

Monitoring Type B

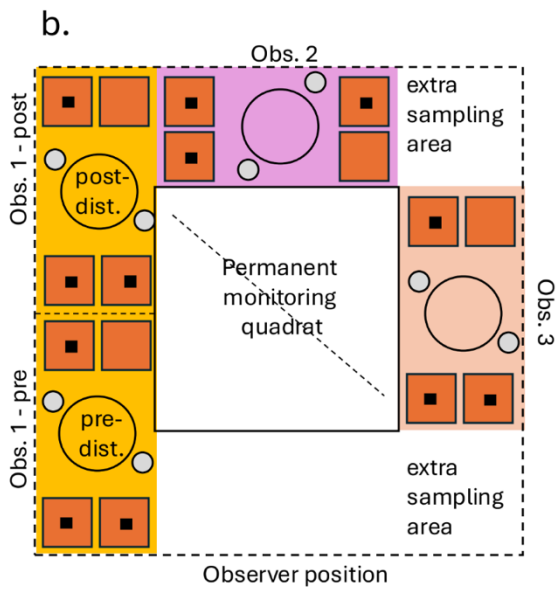

- Take a photo of the plot (70 cm high)
- Measure cover and surface roughness in the permanent monitoring quadrat at the center
- Measure water infiltration, aggregate stability, take N-fix tubes, and take 4 soil samples (each 1 cm deep and 5x5 cm area), pool into a single bag
- Smash
- Post-disturbance monitoring

Appendix 6. Suggested Labeling Systems

1. When writing the date on sample bags, tubes, and datasheets use YearMonthDay as the standard notation.
2. Standardized labeling system for all plots, bags, molecular samples including node lead, three letter site code, plot reference codes and sample number.

Abbreviations:

SF = Structure-function

DR0 = Disturbance-Recovery control plots

DR100 = Disturbance-Recovery (100% disturbance) plots

DRI = Disturbance-Recovery (100% disturbance + inoculation) plots

DG = Disturbance-Gradient

<u>Survey/Experiment</u>	<u>Full Sample ID</u>	<u># of Samples</u>	<u>Depths</u>
Composite	Bowker_MPG_composite	1	0-1 cm
Composite	Bowker_MPG_composite	1	1-5 cm
Structure-Function	Bowker_MPG_SF1	SF1-SF10	0-1 & 1-5 cm
Disturbance Recovery	Bowker_MPG_DR0_1	1-8	
	Bowker_MPG_DR100_1	1-8	
	Bowker_MPG_DRI_1	1-8	
Disturbance Gradient	Bowker_MPG_DG100_1	1-2	
	Bowker_MPG_DG75_1	1-2	
	Bowker_MPG_DG50_1	1-2	
	Bowker_MPG_DG25_1	1-2	
Rainfall Reduction	Bowker_MPG_Rain_1	1-3	yes shelter
	Bowker_MPG_RainC_1	1-3	no shelter

3. Standardized labeling system for all site and plot photos

Tier 1

Last name_node code_YearMonthDay_T1_transect#

Nardi_JBG_20250718_T1_transect1

Last name_node code_YearMonthDay_T1_plot name_shaded or not

Nardi_JBG_20250718_T1_SF1_S shade

Nardi_JBG_20250718_T1_SF1_NS no shade

Tier 2

Last name_node code_YearMonthDay_T2_plot name_shaded or not

Nardi_JBG_20250718_T2_DRI_6_S shade

Nardi_JBG_20250718_T2_DRI_6_NS no shade

Tier 3

Last name_node code_ YearMonthDay _T3_plot name_ shaded or not
 Nardi_JBG_20250718_T3_RAIN1_S shade
 Nardi_JBG_20250718_T3_RAIN1_NS no shade

Other Photos

Note: You do not need to name every single photo that you provide. Please label anything that we might need to communicate about or that you would like us to refer to at a later time. All other photos can remain unnamed.

Node lead_node code_ YearMonthDay _landscape1
 Node lead_node code_ YearMonthDay _people1
 Node lead_node code_ YearMonthDay _unkFORB6
 Node lead_node code_ YearMonthDay _unkMOSS20
 Node lead_node code_ YearMonthDay _cool thing10

We especially appreciate any photos that you provide showing your field crew, the landscape, the plant-biocrust communities, and detailed photos of the mosses and lichens at your site.

4. Structure-Function Plot Names

This may vary based on how you choose to carry out the Structure-Function study.

	low richness	high richness
very low cover	SF 1	SF 2
low cover	SF 3	SF 4
medium cover	SF 5	SF 6
high cover	SF 7	SF 8
very high cover	SF 9	SF 10

Appendix 7. Additional Optional Studies

Spectral reflectance of biocrust types

This study may be completed at the same time as Tier 1 sampling. The target for adequate sampling is about 10-20 nodes with a relatively even geographic spread.

Prospective samplers interested in this portion of the protocol should first email Emilio Rodriguez-Caballero (rce959@ual.es), Bettina Weber (bettain.weber@uni-graz.at) , matthew.bowker@nau.edu and sierra.jech@nau.edu to determine if their sites would be useful additions to the study.

These samples will be used for two different purposes: First, the spectral reflectance of the samples will be analyzed to obtain a database on the spectral impact of biocrusts and their impact on surface albedo on a broader scale. This database may form the basis of a public spectral library. Second, the samples will be used for N cycling analyses. We plan to analyze the gaseous N emissions paired with the N fixation rates of different biocrust types originating from various biocrust localities. This will help us to obtain a much better baseline to quantify biocrust relevance in N cycling at larger spatial scales.

Sampling procedure:

- Identify bare soil and the different biocrust types in the following way, as far as present (similar to the description under 2.3.2 and Büdel et al., 2009, *Microbial Ecology* 57: 229-247).
 - *Bare ground (no biocrust)*: Some filaments may be present in the soil but the quantity is insufficient to aggregate soil. Color of surface soil is identical to underlying soil.
 - *Light cyanobacterial crust*: Biocrust surface is clearly aggregated; if examined more closely, filaments can be detected in the biocrust signifying a major effect of biota on aggregation. Color is patchy with lighter and darker areas, the darker areas getting darker or greenish upon wetting.
 - *Dark cyanobacterial crust*: Majority of biocrust surface is nearly continuously covered by surface bound, dark pigmented cyanobacteria (e.g. *Nostoc*, *Scytonema*) growing over a stable platform engineered by filamentous cyanobacteria (e.g. *Microcoleus*); color is gray to black. May contain cyanobacterial lichens (dark colored, gelatinous, discernable thallus structure) as a minor component.
 - Biocrust with green algal lichens (like *Acarospora*, *Placidium*, *Diploschistes*, *Psora*, *Toninia*, etc.), that often also contains cyanobacteria to some (minor) extent.
 - Bryophyte crust, dominated by liverworts (like *Riccia* etc.; may appear as grey to blackish Y-shaped lobes when dry).

- Bryophyte crust, dominated by mosses (*Bryum*, *Syntrichia*, *Campylopus*, etc).
- Of each crust type and of bare, uncrusted soil collect 8 small (~5.5 cm diameter) samples in petri dishes or small dish. You may collect samples of unique species or mixture of species in the petri dishes. For example, if three mosses co-occur at your site, you may sample a mixed community. If sampling pure species is an option at your site, that is ok too.
 - If using Petri dishes, line the lower lid of the Petri dish with soft cellulose (so that the crust surface doesn't get scratched) and press it upside down into the soil/crust. Push a trowel below the lid, lift it together with the sample from the surrounding soil, turn it upside down and carefully remove surplus soil. Close it with the upper lid, seal it with taping band and mark it with the following code: Node Lead_Node Code_Spectral Reflectance_YearMonthDay_type (e.g., moss1).
 - If your biocrust samples are too tall for a typical petri dish (1 cm thick), then you may need to use a small dish (~5.5 cm diameter). Collect your sample following the petri dish method above, and then pad the top of the dish with tissue or toilet paper to fill any gaps between the top of the biocrust sample and the lid of the container.
 - The samples need to be collected in a dry state or dried before sealing.
 - Emilio Rodriguez-Caballero (rce959@ual.es) should be contacted prior to sampling/shipping. Emilio will arrange the appropriate permits to have these samples imported correctly. Please provide Emilio with your contact information, the GPS coordinates of your node, and the number of samples that you plan to collect/ship (up to 48 per node).

Appendix 8. Rainfall reduction shelter design

Materials for 1 shelter (small size)

Quantity	Pipe Layout	Length (cm)	Description	Purchasing Information
2	Short upright pipes	60	$\frac{3}{4}$ " electrical metallic tubing	Local hardware store
2	Tall upright pipes	95	$\frac{3}{4}$ " electrical metallic tubing	Local hardware store
4	Angle aluminum	91.5 (3')	1.5" x 1.5" x 1/8" thick	Local hardware store
24 slats per roof = twelve 3' tubes per roof = six 6' tubes	Acrylic tubing (3/4" OD, 5/8" ID, 1/16" wall)	91.5 (3')	3/4" OD, 5/8" ID, 1/16" wall Part # 44025	Purchase information available from the Leadership Team
4	Silicone rubber	91.5 (3')	High-Temperature Silicone Rubber Sheets, Bars, and Strips (1/2" x 36", 3/16" Thick)	Purchase information available from the Leadership Team
4	Bolts (attach angle aluminum to EMT legs)	1 1/2" x 1/4" thick	$\frac{3}{4}$ " or 5/16" hex bolts with locking nuts. Size ~1 1/8" or 1 1/4"	Local hardware store
10	Bolts (connect 2 angle aluminum together)	1 1/2" x 1/4" thick	$\frac{3}{4}$ " or 5/16" hex bolts with locking nuts	Local hardware store
4	Rebar	1/2" x 2' 1/2" x 3'	Small enough to slide into the $\frac{3}{4}$ " EMT. Size ~5/16" or 1/4" by 5/16"	Local hardware store
	Glue		Silicone sealant or adhesive (try Lexel)	Local hardware store

If you cannot use rebar to hold the shelters in place, you will have to build a base using more EMT and MakerPipe structural pipe connectors (<https://makerpipe.com/>, purchase information available from the Leadership Team). These are 90-degree connectors (¾"). You also need to buy sandbags. Use sandbags to hold the structure in place against the prevailing wind direction. There will be issues with water flow/pooling with this design. You will need 4 additional pipes for this design:

2	Long base pipes	150	¾" electrical metallic tubing	Local hardware store
2	Short base pipes	125	¾" electrical metallic tubing	Local hardware store
2-4	Sandbags		large sandbags to lay over the base legs and anchor the structure to the ground	Local hardware store

Tools:

- 7/16th hex driver
- 7/16th hex head bolts
- 5 mm hex socket head bolt
- 5 mm Allen wrench – for the 4-way connectors if making the base pipes
- Conduit bender (3/4") – purchase information available from the Leadership Team
- Clamps
- Drill press
 - Use a slower speed for metal (500 rpm) is the lowest setting on the belt
 - Use a level to check that the drill bit is vertical and tighten or loosen the “chucks” to achieve the right position
 - Use a backer board (scrap piece of wood to drill down onto)
 - Rotate the arm to lower the drill bit into position
 - Use clamps to attach the backer and the piece you are drilling to the table
 - Use a vice grip to hold something firmly but keep your hands away from the drill bit
 - Use a twist bit
- Hack saw for acrylic tubing or table saw or band saw
- File for aluminum (smooth single cut file)
 - For cutting EMT, I bought a cutting device from MakerPipe that works well. Could also use a metal saw if needed
- Mask, goggles, and earplugs for cutting acrylic tubes
- Closed toed shoes, long sleeves and pants

Construction:

EMT Legs

1. Cut sections of EMT to 60 and 95 cm
2. Use a conduit bender to bend each end of the EMT to 20 degrees – be careful to get the hole lined up in the correct orientation
3. Use a drill press to drill holes into the EMT with a drill bit slightly bigger than $\frac{1}{4}$ "

Angle Aluminum

1. Drill two holes (slightly bigger than $\frac{1}{4}$ ") into each end of the angle aluminum (at about $1\frac{3}{4}$ " from each end)
 - a. Leave space on the end of the angle, be sure the bolts and nuts will not overlap
 - b. Be sure not to drill too close to the 90-degree angle such that the nuts don't have space to turn. You need enough space for your fingers too!
6. Use a drill press to drill 5 holes all the way through both aluminum angles, clamped together with 3-5 tight clamps along its length
 - a. positions are at about 1", 9.5", 18", 26.5", 35"
7. File off the aluminum burrs that you create while drilling
8. Cut a strip of silicone rubber to 91.5 cm (need 4) – they come as 3' strips, so cutting might not be necessary
9. Glue the silicone rubber strip to the outside face of the angle aluminum, placing the rubber as close as possible to the edge (close to the right angle)
10. When the glue is dry, clamp two aluminum angles together such that the strips are matched. Use more clamps with slightly less force to make them come together tightly.
11. Label the two aluminum angles so that you know they are a pair.

Acrylic slats

1. Use a hack saw to cut 12 tubes to the correct length (91.5 cm) – each tube is 6' long so cut them in half. Other tools that have worked are a band saw and miter saw. If you cut acrylic too slowly, it will melt and be challenging to deal with, so play around with cutting techniques for the acrylic
2. Use a band saw or a table saw with a thin blade to cut the acrylic slats in half (length wise). Do not hand-feed the tubes into the saw. You need a good jig to get reproducible cuts every time. The acrylic is brittle, so you need to be gentle while cutting it. Never try to force a saw blade through the acrylic. Let the teeth do the work. There will be a lot of acrylic dust. Do not let the acrylic tube turn while you are cutting (keep the cut in the most vertical position)
3. You need ~20-35 slats per roof. Cut a few extra in case they break in transit or during assembly.

Appendix 9. Rainfall Reduction Shelter Installation Instructions

1. **Before field work.** Calculate the number of slats needed on the roof. Instructions for this calculation are available on GitHub, [Calculation: CrustNet Rainfall Reduction](#). If your node is outside the United States, please contact the CrustNet leadership team for guidance in accessing long-term climate data.
2. **In the field.** A pair of plots should be assigned as control or drought based on their location relative to one another and the sun's path through the sky. If they are close to one another, there is a risk that the drought structure will create significant shade on the control plot. Your control plot should be to the south of the drought plot, so that the shelter's shade will not cross over the control plot. You might consider facing the short side of the structure toward the north to minimize plot shading under the structures.

Once you have selected plot locations, you can construct the shelters.

Guidelines for using rebar:

- Connect two pairs of aluminum angels with 3 bolts each. The nuts can be loosely attached so that the aluminum angles slide apart and together easily along the length of the bolt.
- Pound one piece of 90 cm (3') rebar into the ground, leaving 45 cm (~1.5') above ground. Slide a long leg over the rebar.
- Measure the approximate distance to the second long leg (using the aluminum angle) and pound the second 3' rebar into the ground, leaving 45 cm (~1.5') above ground. Slide a long leg over the rebar.
- Connect a set of aluminum angles to these long legs with 2 bolts (see the diagram for the orientation).
- Again, measure the distance needed for the set of short legs. Use the slats, which are ~76 cm long. They will be installed at an angle and will need ~10 cm of hanging length past the leg position for the water to drip off the plot (see the diagram). Pound in the 60 cm (2') rebar in the correct positions, leaving ~ 30 cm (1') above ground. Slide the short legs over these rebar pieces.
- Loosen all bolts so that there is space to slide the plastic slats between them. Start on one end and slide in the plastic slats. Tighten bolts as you go so that they stay put. Once all slats are in place, tighten all the bolts substantially. You can use locking nuts to ensure they stay together in the field.

Guidelines for using sandbags

- If you cannot use rebar at your site, you'll need to construct a base on your drought shelters using long 152 cm (5') EMT and 4-way connectors. The short and long legs of the shelters will connect to the base. See the diagram for guidance.
- The rest of the shelter will be constructed in the same way as described above.
- Sandbags can be filled with dirt from the site and placed on each leg of the structure to hold it in place.
- Monitor both the control and drought plot as you did in the Tier 2. Disturbance Gradient experiment. Do not collect N-fix tubes.

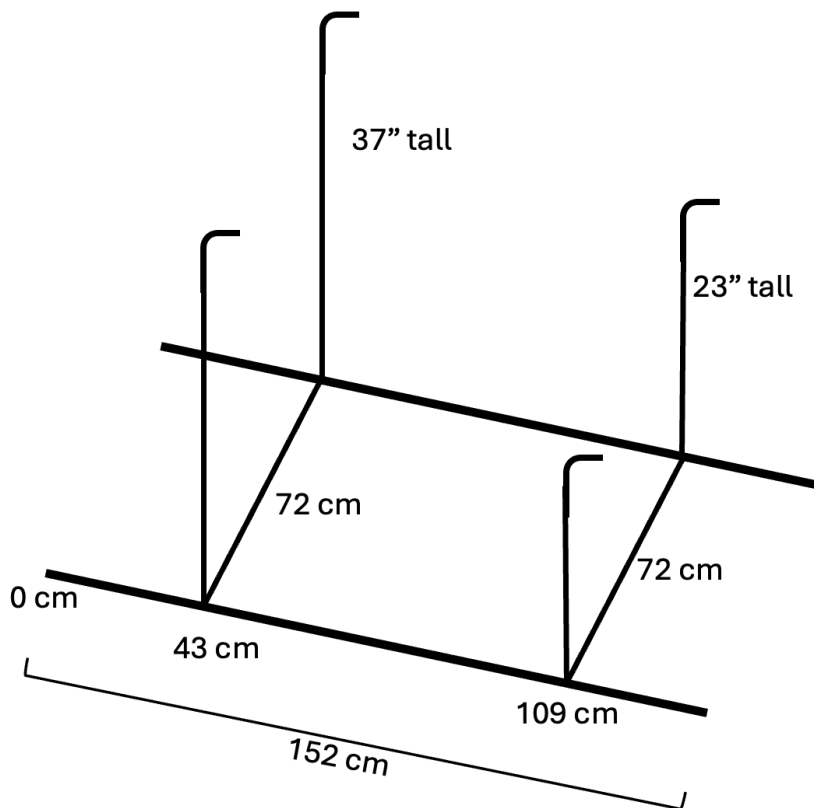

Figure A9.1. Rainfall reduction shelter with base legs instead of rebar.



Figure A9.2. Shelter orientation with short legs facing north to minimize plot shading.

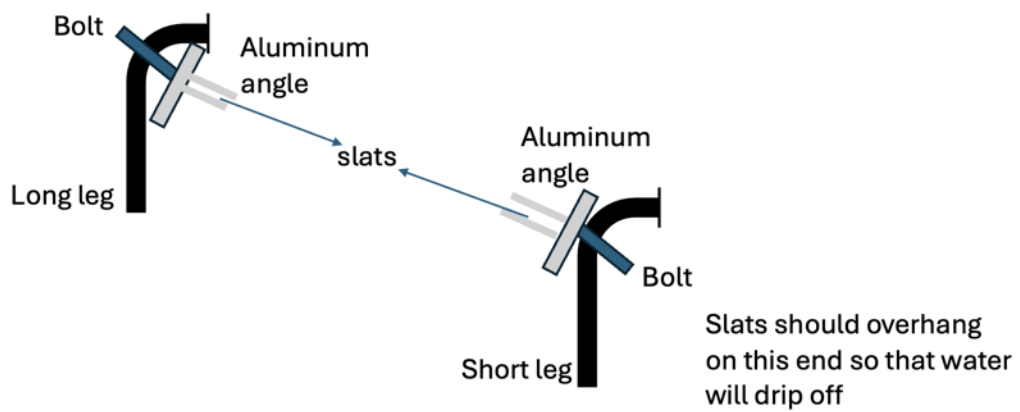

Figure A9.3. Orientation of the bolts, aluminum angles, and slats in relation to the long and short legs of the shelter.



Figure A9.4. Images to help with rainfall structure construction. Note that there is no hardware keeping the roof slats in place, they are just squeezed between the metal pieces.

Appendix 10. Instructions for Shipping Imported CrustNet Samples.

The United States uses a strict protocol for importing foreign soil for research purposes. **You must follow these instructions carefully for all samples being sent to the USA!** If you do not, the samples could be destroyed, wasting your work, and our soil import permit could be revoked.

Do not ship spectral reflectance samples to NAU. Please follow the instructions in Appendix 7 and contact Emilio Rodriguez-Caballero for separate shipping instructions.

The shipping address for all CrustNet samples is:

Permitted recipient:
Matthew Bowker
School of Forestry
200 E. Pine Knoll, Box 15018
Northern Arizona University
Flagstaff, AZ 86011

Contact information: 928 525 6048

All samples need two levels of packaging and BOTH the primary and secondary packaging have to be leakproof. Some of our sampling containers do not count as primary packaging because they are not leakproof (i.e., petri dishes, N-fix tubes, tackle boxes) so they need to have two layers of bags.

1. **Have the right documents and labels.** Make sure you have a copies of NAU's USDA soil import permit (525-22-318-20470R1_A-00741759_11-12-2025) and Black & White labels (PPQ form 550). We should have either sent physical copies or emailed digital copies for you to print. If you don't have these, please contact us right away:

matthew.bowker@nau.edu

(cc: sierra.jech@nau.edu, ella.santana-propper@nau.edu)

What are these, and why do you need them?

- a. *The permit is granted to NAU to be able to receive foreign soil for research purposes. It establishes conditions for shipping & handling soils, storing them, and eventual disposal. The permit requires that a copy of the permit is included with each shipment.*
- b. *The Black and White (PPQ 550) labels are specific to a specific shipment from one group in one place at one time to NAU. NAU must request them from USDA, specifically for your shipment, then give them to you. You cannot*

use PPQ labels given to someone else, nor labels given to you for a previous shipment or a shipment from another place. Each shipment from a given location requires unique PPQ labels. The labels tell customs agents that the boxes require inspection by USDA officials, and they are required to be visible on the exterior of any shipment. The label also functions as the receiver's address (NAU).

Note: all instructions below assume that samples have been air-dried, and that samples are well-labeled.

2. **Prepare soil samples for shipping** (refers to 0–1 cm, or 1–5 cm soil samples in sealing bags [e.g., Ziploc or similar product]). Make sure each one is well-sealed, and that none are leaking or have holes. Put the bags into a second layer of sealing bags; several smaller bags may be contained in larger bags. **Double bagging** is meant to ensure that samples are redundantly leak-proof.

3. **Prepare trait samples for shipping** (refers to intact specimens of biocrusts – bryophytes and lichens - with underlying soil attached). Our goal is to keep samples intact and protected, and at the same time, contained in redundant, leak-proof packaging. Samples will be variable from place to place, so you have some discretion about how to achieve this. One way is below:
 - Individually wrap each specimen in tissue paper.
 - To keep the sample from falling out of this wrapping, it is advisable to either place a small piece of masking tape (paper tape used by painters) or a similar type of tape like laboratory labelling tape around the paper-wrapped sample, securing some of the loose edges of tissue paper. Partially wrapping a small piece of aluminum foil around the specimen also works well. This is the only case in which you do not need a complete label on each individual specimen but do keep specimens of the different species separated. A brief label is advisable (for example SR, indicating *Syntrichia ruralis*).
 - Place the individual specimens of a given species into a plastic food container, with a lid that snaps closed. Various sizes exist, so it should be possible to find a size suitable for the amount of material you must package. In leftover space, gently place lightweight cushioning materials around the samples to reduce shaking and shock.
 - Close the lid, using tape to reinforce the closure. Completely label the plastic container.
 - Put plastic containers into a plastic bag (Ziplock or similar) to achieve a redundant leak-proof state. Note: If your samples are in petri dishes that are not leak proof, then you must add two layers of plastic bags in order to be redundantly leak-proof.

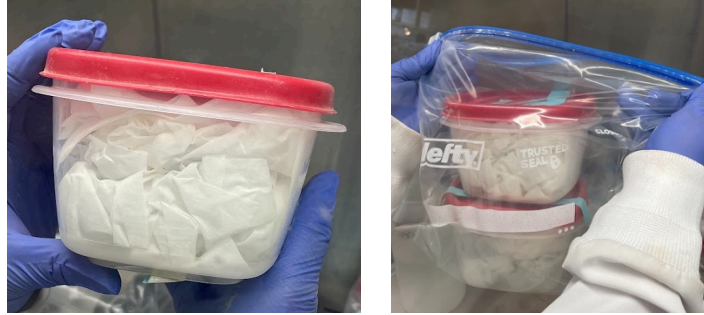

Left) The Tupperware container counts as one leakproof layer. You must add a second layer (plastic bag) to meet our shipping requirements as shown on the right.

Prepare N-fix tubes for shipping. You were provided with several cylindrical plastic tubes to sample intact cores, along with rubber stoppers to seal both sides. There should be cushioning material (such as tissue paper) in between the top of the sample and the upper stopper to reduce movement and absorb shock. Seal the tubes in batches inside plastic sealable bags (e.g., Ziplock). Seal the bag within a second bag. Double bagging is meant to ensure that samples are redundantly leak-proof. Position the tubes upright in the package.



The image shows N-fix tubes in one layer of leakproof containment. You must add a second plastic bag to meet our shipping requirements.

4. **Prepare molecular samples for shipping.** You were provided with centrifuge tubes in which to place small subsamples of soil, preserved with RNALater. Double check the lids are closed on these tubes and that each tube has been redundantly labeled. Then, place batches of these tubes into sealing bags and seal. Place all bagged batches into one larger sealing bag and seal. Double bagging is meant to ensure that samples are redundantly leak-proof.
5. **Double check.** Please verify, is every sample **packaged in a redundantly-leak proof fashion?** If not, please make it so.

6. **Box them.** Contain all samples together into a cardboard box, ensuring that it has no tears or punctures, and close all seams with packing tape. Put lightweight cushioning materials in the box in leftover spaces to prevent the movement of samples within.
7. **Additional documents inside the shipment.** Also place the following in the box, on top:
 - a. A sheet of paper with the following:

Permitted recipient:
Matthew Bowker
School of Forestry
200 E. Pine Knoll, Box 15018
Northern Arizona University
Flagstaff, AZ 86011

Contact information: 928 525 6048
matthew.bowker@nau.edu
(cc: sierra.jech@nau.edu, ella.santana-propper@nau.edu)

FedEx Account Number: available from the Leadership Team
 - b. A copy of the soil import permit (525-22-318-20470R1_A-00741759_11-12-2025; referred to in step 1).
 - c. A packing list. List the kinds of samples you have in the box (dry bagged soil samples, intact soil cores, vials of soil with preservative, biocrust samples with underlying soil) the approximate amount of each (mass or volume) and how many of each.

You do **NOT** need: A phytosanitary certificate.

8. **Seal and label the box.** Tape the cardboard box shut. Cut out and securely attach the supplied Black & White labels to the exterior of the box. Apply clear plastic packing tape over these labels to secure them. Do this on at least 2 sides of the box, in case one is damaged. Ensure that there is no other additional address information on the package exterior.

Send the samples and let us know! We recommend using FedEx as the courier. **You can use our FedEx account number to pay for sending the packages:** available from the Leadership Team. This account belongs to ECOSS at NAU. If FedEx does not operate in your country, please contact us so we can make an alternative plan. Email us (matthew.bowker@nau.edu, sierra.jech@nau.edu, ella.santana-propper@nau.edu) with the shipment date, carrier, and tracking number so we can watch for the package.

9. When sending your package with FedEx or another courier, you will almost certainly be asked to provide a value for the shipment, for taxation and importation purposes. We recommend specifying a nominal small, but non-zero value such as \$1.
10. Finally, when shipping samples into the United States, we must certify that the shipment is compliant with the Toxic Substances Control Act (TSCA) because some of the samples will have been treated with a chemical preservative. Although either the sender (you) or receiver can provide this certification, we have found that in practice it can be helpful for the sender to do so (the package is less likely to be delayed). We will provide you with a TSCA certification form to present to the courier, along with four Safety Data Sheets about the chemical preservative as supporting documents.

Appendix 11. Ocular Cover Estimate Guide

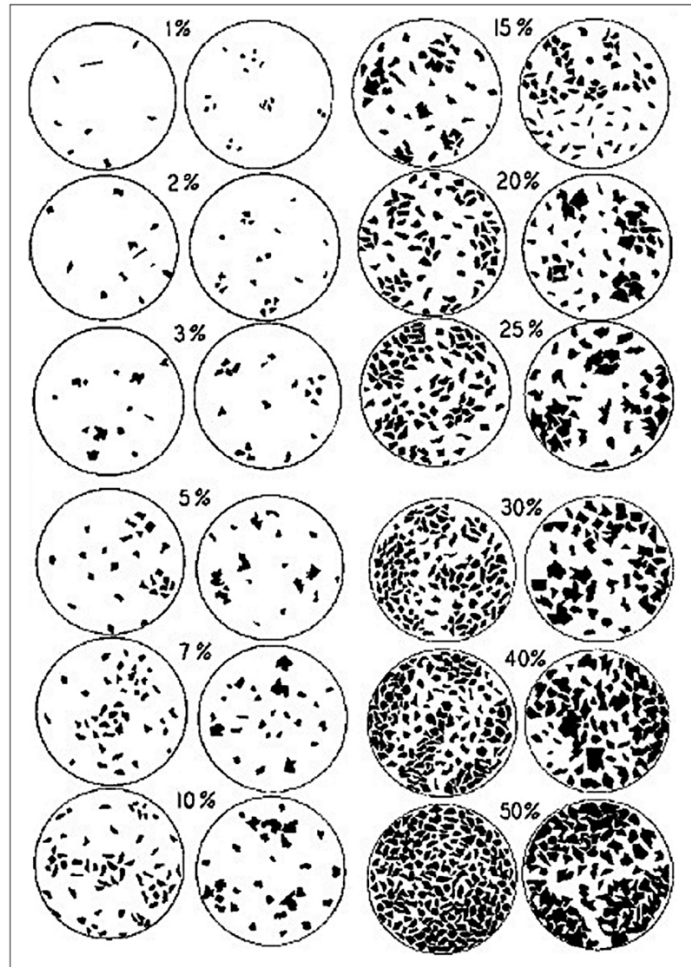

FIA = Forest Inventory and Analysis.

This figure is from the USDA Forest Service Forestry Inventory and Analysis manual (2003). Use these examples of percent cover to guide your ocular estimates of biocrust types for the plant-biocrust co-occurrence survey. We recommend printing a copy of this figure for the field.

USDA Forest Service. 2003. Forest Inventory and Analysis national core field guide, volume 1: field data collection procedures for phase 2 lots, version 1.7. Internal report. Washington, DC: U.S. Department of Agriculture, Forest Service, Washington Office. <http://fia.fs.fed.us/library/field-guides-methods-proc/>.